



# Busy Bee Tools

## 14" Professional Band Saw

### BBPBS14N



## User's Manual



COPYRIGHT © 2024 BY BUSY BEE TOOLS LTD.

NO PORTION OF THIS MANUAL MAY  
BE REPRODUCED WITHOUT THE WRITTEN  
CONSENT OF BUSY BEE TOOLS LTD.



v2.0



## General Shop Safety Instructions

Notice: Safety First! The paramount concern in operating this equipment is safety. It is imperative to adhere strictly to the following instructions. Neglecting any of the listed guidelines may lead to risks such as electric shock, fire hazards, or severe personal injury.

This tool is specifically designed for certain applications. We emphasize the importance of refraining from modifying or repurposing the tool for any other use beyond its designated application. If you have inquiries regarding its appropriate application, refrain from using the tool until you have communicated with us and received our guidance. Please refer to the below safety symbols



**CAUTION**

This warns of an urgent hazard that, if not addressed, may cause death or serious injury. Immediate action is required to avoid danger.



This signifies a potential hazard that could lead to death or serious injury if ignored. Caution is advised to prevent harm.



This highlights a possible hazard that, if not avoided, could cause minor or moderate injury. Care should be taken to reduce the risk.

*Please Note that this manual has some instructions and processes to help you maintain and prolong the life of your machine please perform all the recommended cleaning and maintaining processes diligently.*

# Table of Contents

General Shop Safety Instructions . . . . .	2
Introduction . . . . .	4
Contact us . . . . .	4
General machine information . . . . .	5
Controls and components . . . . .	6
<b>Section 1: Safety . . . . .</b>	<b>7</b>
Self protection and safety instructions . . . . .	9
<b>Section 2: Power Supply and Electrical Safety . . . . .</b>	<b>9</b>
Machine Pre-Wiring and Circuit Requirements . . . . .	10
Electric Motor Information . . . . .	11
<b>Section 3: Unpacking and Set Up . . . . .</b>	<b>12</b>
Assembly Instructions . . . . .	13
Adjustment Instructions . . . . .	16
<b>Section 4: Operations . . . . .</b>	<b>24</b>
Basic Cutting Tips . . . . .	25
Blade Selection & selection Chart . . . . .	26
Ripping . . . . .	27
Crosscutting . . . . .	28
Cutting Curves . . . . .	28
Stacked Cuts . . . . .	29
Resawing . . . . .	29
<b>Section 5: Accessories . . . . .</b>	<b>30</b>
<b>Section 6: Maintenance . . . . .</b>	<b>30</b>
Scheduling . . . . .	30
Cleaning and protecting . . . . .	31
Specific Maintenance for Band Saw . . . . .	33
<b>Section 7: Service . . . . .</b>	<b>34</b>
<b>Section 8: Wiring and Electrical Diagram . . . . .</b>	<b>34</b>
<b>Section 9: Machine Diagrams and Parts . . . . .</b>	<b>36</b>
<b>Section 10: Troubleshooting Guide . . . . .</b>	<b>49</b>
<b>Section 11: Warranty and Return Policy . . . . .</b>	<b>52</b>



# Introduction

It is with distinct honor and excitement that we present to you the BBPBS14N, a premier addition to our esteemed line of precision woodworking equipment. At Busy Bee Tools, we are committed to engineering excellence, and this machine exemplifies our dedication to providing craftsmen with superior tools for their trade.

This manual has been meticulously crafted to guide you through the setup, safe operation, and maintenance of your new BBPBS14N. By following the detailed instructions and recommendations contained within these pages, you can anticipate many years of dependable and satisfying performance. This commitment to quality underscores Busy Bee Tools' promise of enhancing customer satisfaction through innovation and reliability.

This manual includes precise specifications, illustrations, and photographs representing the BBPBS14N in its current configuration. Please note, that in our pursuit of continual improvement and to exceed industry standards, Busy Bee Tools reserves the right to make enhancements to this model without prior notice.

For your convenience, we continuously update all our product manuals which are available on our website at [www.busybeetools.com](http://www.busybeetools.com). We encourage you to visit this site regularly to download the latest updates and ensure that you are always informed about the best practices for operating and maintaining your machine. At Busy Bee Tools, your safety and satisfaction are our utmost priority, and we are dedicated to ensuring that your experience with the BBPBS14N is exceptional.

**Welcome to the Busy Bee Tools family, where craftsmanship meets innovation.**

## Contact Us

In case you require additional assistance or have any further questions, please do not hesitate to reach out to our dedicated Customer Service and Technical Support Department at:

Busy Bee Tools Head Office  
130 Great Gulf Drive  
Concord ON, L4K 5W1

Or at any of our stores across Canada.

Visit our website for the latest deals and for more information. Call us Toll Free: 1-800-461-2879.

Email us at: [cs@busybeetools.com](mailto:cs@busybeetools.com)

Our team of experts is here to provide you with the guidance and support you need to ensure the safe and efficient operation of your machine. Your satisfaction and safety are our top priorities, and we are committed to assisting you in any way we can.



# General Machine Information

Motor .....	1.75 HP, TEFC
Motor Speed (no load) .....	1,700 RPM
Volts .....	120 VAC
Amps.....	14 A,
Hertz, Phase .....	60 Hz, 1Ph
Blade Length .....	111" (2,819 mm)
Blade Width .....	3/16" - 3/4" (4.78 - 19 mm)
Blade Speed .....	1510 / 3185 ft/min ( 460/ 970 m/min)
Table Size (W x D).....	21-1/2" x 15-3/4" (546 x 400 mm)
Table Tilt .....	Left -5° , Right 45°
Miter Gauge T-Slots (2) .....	3/4" x 3/8"
Maximum Cutting Width (throat).....	13-5/8" (346 mm)
Maximum Cutting Depth (height) .....	13" (330 mm)
Table Height .....	39-1/2" (1,003 mm)
Fence Height.....	6" (152 mm)
Fence Length .....	18-3/4" (476 mm)
Dust Ports (1) .....	4" Diameter (100 mm)
Base Size (LxWxH) .....	21-5/8"x14-3/4"x19-11/16" (549x375x500 mm)
Height.....	75" (1,905 mm)
Size (LxWxH) .....	30" x 25" x 75" (762 x 635 x 1,905 mm)
Net Weight .....	285 lb. (129 kg)
Gross Weight .....	293 lb. (133 kg)
Sound Pressure Level (no load).....	≤ 80dB (A)
Sound Pressure Level (load).....	≤ 90dB (A)
Sound Power Level (no load) .....	≤ 90dB (A)
Sound Power Level (load) .....	≤ 100dB (A)



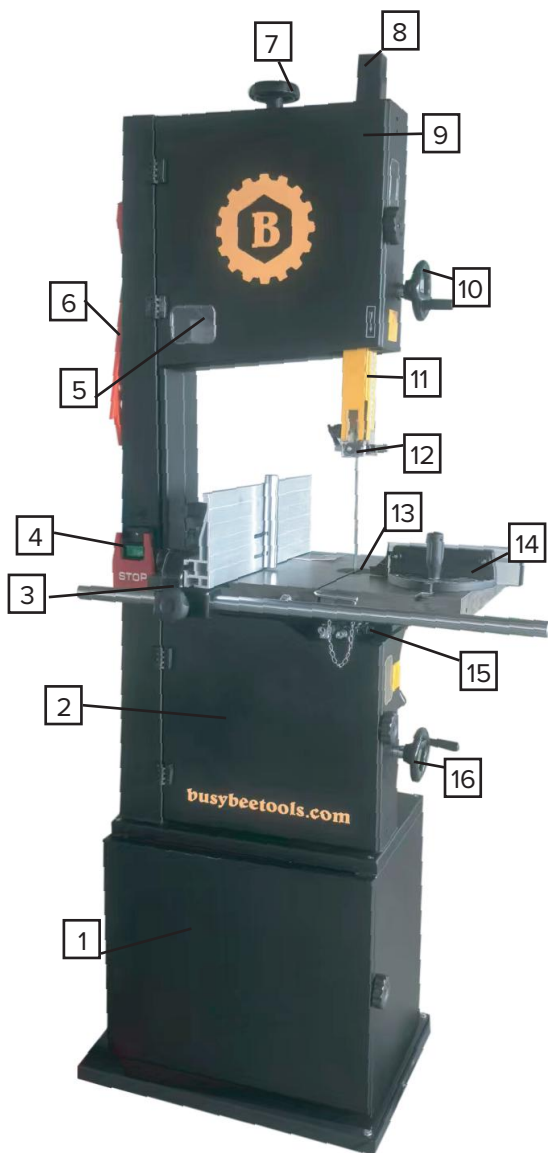

Figure 1: BBPBS14N Front view.

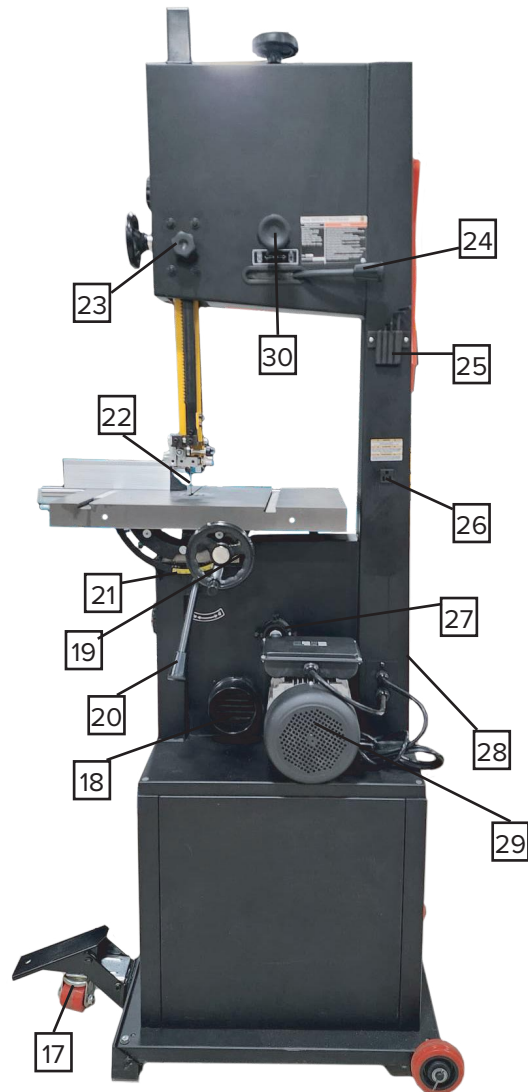

Figure 2: BBPBS14N Rear view.

## Controls and Components

- 1- Stand with storage.
- 2- Lower Wheel Door.
- 3- Rip Fence and Rail Assembly.
- 4- ON/OFF Switch.
- 5- Blade Tension Window.
- 6- Push Stick and Storage Hanger Bolt.
- 7- Blade Tension Knob.
- 8- Guidepost Cap.
- 9- Upper Door and Blade tracking window.
- 10- Blade Guard Adjustment Handle.
- 11- Blade Guard with Scale.
- 12- Upper Blade Guide.
- 13- Table with Insert.
- 14- Miter Gauge Slot.
- 15- Lower Blade Guide and Guard.
- 16- Drive belt Tension Hand Wheel.
- 17- Mobile Kit (Sold Separately).
- 18- 4" Dust Port.
- 19- Table Tilt Wheel.
- 20- Table Locking Handle.
- 21- Trunnion with Angle Scale.
- 22- Band Saw Blade.
- 23- Guidepost Lock Knob.
- 24- Quick Release Blade Tension Leaver.
- 25- Tool Holder.
- 26- Electrical Outlet.
- 27- Lower Wheel Shaft Fasteners.
- 28- Power Cord.
- 29- Motor.
- 30- Blade Tracking Handle and Lock Leaver.



# Section 1: Safety

## General Shop Safety instructions

Your safety is of utmost importance. Prior to starting the assembly of this machine, it is imperative that you thoroughly read the instruction manual. Safety symbols and signal words have been incorporated into this manual to draw your attention to potentially hazardous conditions and to convey the significance of the safety messages. It is essential to remember that these safety messages alone cannot eliminate danger and should not replace the implementation of proper accident prevention measures.



(Minor or Moderate Injury): This symbol indicates a potentially hazardous situation that, if not avoided, **MAY** result in minor or moderate injury. It may also serve as a warning against unsafe practices.



Warning Symbol (Death or Serious Injury): The warning symbol signifies a potentially hazardous situation that, if not avoided, **COULD** result in death or serious injury.



Danger Symbol (Imminent Death or Serious Injury): The danger symbol is used to indicate an imminently hazardous situation that, if not avoided, **WILL** result in death or serious injury.

## General Machine Safety Instructions

1- Thoroughly Review the Entire Manual Before Operating Machinery: It is crucial to read and understand the complete manual before commencing any machinery operations. Machinery can pose serious injury hazards to individuals who lack proper training and familiarity with its operation.

2- Always utilize CSA Approved Safety Glasses During Machinery Operation: For your safety, it is imperative to wear safety glasses that meet ANSI (American National Standards Institute) standards when using machinery. Conventional eyeglasses are not equipped with impact-resistant lenses and should not be considered a substitute for proper safety glasses.

3- Always Wear a CSA Approved Respirator When

Operating Dust-Producing Machinery: When operating machinery that generates dust, it is essential to wear a respirator that has been approved by NIOSH (National Institute for Occupational Safety and Health). Wood dust is classified as a carcinogen and can lead to cancer and severe respiratory illnesses.

*Your respiratory protection is paramount to your health and safety.*

4- Utilize Hearing Protection When Operating Machinery: Always wear hearing protection when operating machinery. Prolonged exposure to machinery noise can result in permanent hearing damage, and protecting your hearing is vital for your long-term well-being.



5- Adhere to Proper Apparel Guidelines: Avoid wearing loose clothing, gloves, neckties, rings, or jewelry that could potentially become entangled in moving parts of the machinery. Additionally, wear a protective hair covering to confine long hair and ensure you have non-slip footwear to prevent accidents.

6- Do Not Operate Machinery When Fatigued, or Under the Influence of Substances: Never operate machinery when you are tired, or if you are under the influence of drugs or alcohol. It is crucial to be always mentally alert when running machinery to maintain your safety and the safety of those around you.

7- Authorize Trained and Supervised Personnel Only: Permit only individuals who have received proper training and supervision to operate machinery. Ensure that operational instructions are not only safe but also clearly understood by those using the equipment.

8- Keep Children and Visitors at a Safe Distance: Maintain a safe distance between all children and visitors and the work area where machinery is in use.

9- Secure Your Workshop for Child Safety: Take measures to childproof your workshop, including the use of padlocks, master switches, and the removal of start switch keys to prevent unauthorized use by children.

10- Never Leave Machinery Running Unattended: It is essential never to leave machinery unattended while it is still running. Turn off the power and allow all moving parts to come to a complete stop before leaving the machine unattended.



11- Avoid Dangerous Environments: Refrain from using machinery in locations that are damp, wet, or where flammable or noxious fumes may be present. Always ensure a safe operating environment.

12- Maintain a Clean and Well-Lit Work Area: Keep your work area clean and well-lit to prevent accidents. Clutter and dark shadows can pose significant safety risks.

13- Use Properly Rated Extension Cords: When necessary, use a grounded extension cord rated for the amperage of the machine. Undersized cords can overheat and lose power. Replace damaged extension cords promptly. Do not use extension cords with 220V machinery.

14- Disconnect from Power Source Before Servicing: Always disconnect the machinery from the power source before servicing it. Ensure the switch is in the OFF position before reconnecting.

15- Maintain Machinery with Care: To ensure the best and safest performance, maintain your machinery with care. Keep blades sharp and clean and follow the manufacturer's instructions for lubrication and changing accessories.

16- Verify Guards Are in Place and Functional: Before using machinery, confirm that all safety guards are in place and functioning correctly. Never operate machinery if guards are missing or not working as intended. Your safety relies on the proper functioning of these guards.

17- Remove Adjusting Keys and Wrenches: Prior to turning on the machinery, it's essential to cultivate the habit of checking for adjusting keys and wrenches and ensuring they are removed. Leaving such tools in place can result in accidents.

18- Inspect for Damaged Parts Before Use: Before using the machinery, conduct a thorough inspection for damaged parts. Check for any issues such as binding or misalignment of parts, broken components, improperly mounted parts, loose bolts, or any other conditions that might impact the safe operation of the machine. Any damaged parts should be promptly repaired or replaced.

19- Utilize Recommended Accessories: Consult the instruction manual to identify the recommended accessories for your machinery. Using improper accessories can pose a risk of injury, so it's essential to adhere to the manufacturer's recommendations.

20- Avoid Forcing Machinery: Operate the machinery at the speed for which it was designed and avoid forcing it beyond its intended capabilities.

21- Secure the Workpiece: Whenever possible, use clamps or a vise to secure the workpiece. A properly secured workpiece not only protects your hands but also allows you to use both hands to operate the machine safely.

22- Avoid Overreaching: always Maintain proper footing and balance. Overreaching can compromise your stability and pose a risk of accidents.

23- Beware of Workpiece Ejection: Be aware that certain machines may eject the workpiece toward the operator. Take precautions and avoid conditions that could lead to workpiece "kickback."

24- Lock Mobile Bases (If Used) Before Operation: If your machinery is equipped with mobile bases, ensure they are locked securely before operating the equipment. This prevents unintended movement during use.

25- Understand Dust Hazards: Recognize that some dust types can be hazardous to respiratory systems, both for people and animals, particularly fine dust particles. Familiarize yourself with the hazards associated with the specific type of dust you will be exposed to and always wear a respirator approved for that specific type of dust to protect your respiratory health.

#### **Bandsaw Specific Safety instructions.**

This machine is designed for cutting natural solid woods, composite materials, plastics, and non-ferrous metals within the permissible workpiece dimensions specified in the Technical Specification. Any use other than as specified, including modification of the machine or use of unapproved parts, may result in unforeseen damage and void the warranty.



*Attention: Despite manufacturer efforts, risks*

*associated with the use of this band saw remain. Users must exercise caution as woodworking machines can be hazardous if not operated with care and adherence to safety precautions. Before operating the machine, carefully read and understand all instructions provided herein.*

1. Refrain from operating the machine until all instructions have been thoroughly reviewed.

2. Seek assistance from a qualified individual if unfamiliar with the machine's operation.

3. Always wear approved safety eyewear and hearing protection during machine operation.



4. Use a dust mask, ensure proper dust collection, and maintain adequate ventilation.
5. Set the upper guides approximately 1/8" to 1/4" above the material being cut.
6. Verify the correct blade size and type for the material's thickness and composition.
7. Ensure proper adjustment of blade tension and tracking.
8. Always keep hands and fingers away from the blades.
9. Execute "relief" cuts before cutting curves to prevent blade binding.
10. Securely hold the material flat on the table and feed it into the blade at a moderate pace.
11. Avoid sawing stock without a flat surface unless supported adequately.
12. Use push sticks, holding jigs, or similar devices when cutting small workpieces to keep hands safely away from the blade. Employ "Zero Clearance Inserts" when possible to prevent small pieces from becoming lodged.
13. Allow the bandsaw blade to come to a complete stop before removing scrap pieces from the table.
14. Do not attempt to clear jammed pieces until the machine and blade have stopped. Disconnect the bandsaw from the power source before removing jammed workpieces.
15. Turn off the machine if material needs to be backed out of an incomplete cut.
16. Provide additional support, such as roller stands or sawhorses, for large workpieces susceptible to tipping.
17. Always deactivate and unplug the machine before blade changes or servicing.
18. Release blade tension when the saw will not be used for an extended period.
19. Keep the work area free of debris and maintain cleanliness.

### **Self protection and safety instructions**

When operating a woodworking bandsaw, ensuring personal safety is paramount. Prior to use, familiarize yourself with the machine's safety features and operational manual. Wear appropriate personal protective equipment

(PPE) such as safety glasses to shield eyes from wood chips and debris, hearing protection to minimize noise exposure, and snug-fitting clothing to avoid entanglement hazards. Keep the work area well-lit and clear of clutter to facilitate safe movement and operation. Utilize push sticks or push blocks to guide materials through the saw, maintaining a safe distance between your hands and the blade. Never remove or bypass machine guards, and always wait for the blade to come to a complete stop before making adjustments or clearing debris. Regularly inspect the band saw for any signs of damage or wear, and promptly address any issues to ensure continued safe operation. Remember, prioritizing safety precautions and equipment usage significantly reduces the risk of accidents and injury while using a woodworking bandsaw.

At busybeetools.com we carry a wide range of PPE to help you stay safe and injury free.

## **Section 2: Power Supply**

### **Availability and Installation of Power Supply**

Before proceeding with the installation of this machine, it is crucial to assess the availability and proximity of the required power supply circuit. If an existing electrical circuit does not meet the specifications and requirements for this machine, the installation of a new circuit becomes necessary.

To minimize the potential risks of electrocution, fire, or equipment damage, it is imperative that all installation work and electrical wiring be carried out by a certified electrician or qualified service personnel. The installation must fully comply with all applicable electrical codes and standards in your area.

This proactive approach ensures the safety, reliability, and proper functioning of the machine while also mitigating the risks associated with improper electrical work.

### **Full-Load Current Rating**

The full-load current rating is the amperage that a machine draws when it operates at 100% of its rated output power. In machines equipped with multiple motors, this rating represents the amperage drawn by the largest motor or the cumulative amperage of all motors and electrical devices that may operate simultaneously during regular operations.

Full-Load Current Rating at 110V: 19 Amps

Full-Load Current Rating at 220V: 9.5 Amps



It is important to note that the full-load current rating does not represent the maximum amperage that the machine can draw. If the machine is subjected to an overload, it may draw additional amperage beyond its full-load rating.

Continued operation under overloaded conditions can lead to damage, overheating, or even fire, especially if the machine is connected to an undersized electrical circuit. To mitigate these potential hazards, it is imperative to avoid overloading the machine during operation and ensure that it is connected to a power supply circuit that meets the specified circuit requirements outlined in the machine's documentation.

### Power Supply Circuit Sizing

The power supply circuit encompasses all electrical components between the building's breaker box or fuse panel and the machine itself. The power supply circuit employed for this machine must be appropriately sized to safely accommodate the full-load current drawn from the machine over an extended duration.

If your machine is connected to a circuit protected by fuses, it is recommended to use a time delay fuse specifically marked with the letter "D." This type of fuse provides additional time delay before tripping, which can be beneficial when dealing with equipment that may experience momentary current spikes during startup.

Ensuring that the power supply circuit is properly sized and protected is vital for the safe and efficient operation of the machine while minimizing the risk of electrical issues or circuit overload.

#### **Important Note: Dedicated Circuit vs. Shared Circuit**

The circuit requirements specified in this manual pertain to a dedicated circuit, which is designed for the exclusive use of a single machine at any given time. In this scenario, only one machine is intended to operate on the circuit.

However, if your machine is to be connected to a shared circuit where multiple machines may run simultaneously, it is imperative to seek the expertise of an electrician or a qualified service personnel. Their guidance is essential to ensure that the circuit is properly sized and configured to facilitate the safe operation of all machines concurrently.

The input and advice of professionals in such cases are crucial for preventing electrical overloads, ensuring safety, and promoting the efficient functioning of the machinery within a shared electrical system.

### Machine Pre-Wiring and Circuit Requirements

- Nominal Voltage: 110V, 115V, 120V
- Cycle: 60 Hz
- Phase: Single-Phase
- Power Supply Circuit: 20 Amps
- Plug/Receptacle: NEMA 5-20

### Circuit Requirements for 220V:

Please consult with a certified professional electrician before attempting to switch the power requirement.



- Nominal Voltage: 208V, 220V, 240V
- Cycle: 60 Hz
- Phase: Single-Phase
- Power Supply Circuit: 15 Amps
- Plug/Receptacle: NEMA 6-15

This machine has the capability to be converted to operate on a power supply circuit that meets these requirements. Detailed instructions for voltage conversion can be found in the provided Voltage Conversion instructions. Ensuring that the power supply circuit aligns with these specifications is essential for safe and effective operation when operating at 220V.

These requirements are essential for the safe and optimal operation of the machine. It is crucial to ensure that the power supply circuit adheres to these specifications to prevent electrical issues and promote the efficient functioning of the equipment.

### Grounding Requirements

This machine **MUST** be grounded. In the event of certain malfunctions or breakdowns, grounding reduces the risk of electric shock by providing a path of least resistance for electric current.

#### For 110V operation

This machine is equipped with a power cord that has an equipment-grounding wire and a grounding plug (see the following figure). The plug must only be inserted into a matching receptacle (outlet) that is properly installed and grounded in accordance with all local codes and ordinances.

#### For 220V Operation and Grounding

When operating this machine at 220V, it is crucial to ensure proper grounding and electrical connections. Here are the steps to follow:



1. The plug specified in the “Circuit Requirements for 220V” section, which includes a grounding prong, must be attached to the equipment-grounding wire on the provided power cord.

2. The plug should only be inserted into a matching receptacle, as described in the following figure. This receptacle must be correctly installed and grounded in strict accordance with all local electrical codes and ordinances.

By adhering to these grounding and electrical connection instructions, you can ensure the safe and reliable operation of the machine at 220V while complying with local regulations and safety standards.

### Safety Precautions

It is of utmost importance to ensure the correct and safe connection of the equipment-grounding wire to prevent the risk of electric shock. Here are some crucial guidelines:

1- Identify the Equipment-Grounding Wire: The wire with green insulation (with or without yellow stripes) is designated as the equipment-grounding wire.

2- Power Cord or Plug Repair/Replacement: If repair, or replacement of the power cord or plug is necessary, it is essential not to connect the equipment-grounding wire to a live (current-carrying) terminal. Doing so could pose a severe electric shock hazard.

3- Seek Professional Assistance: If you have any doubts or uncertainties regarding these grounding requirements, or if you are unsure whether the tool is properly grounded, it is strongly recommended to consult with a qualified electrician or a service personnel for guidance and assistance.

4- Monitor Cord and Plug Condition: Regularly inspect the power cord and plug for any signs of damage or wear. If you notice any issues, immediately disconnect the cord from power and replace it with a new one to maintain safety.

By following these safety precautions and ensuring the correct grounding of the equipment, you can significantly reduce the risk of electric shock and maintain the safe operation of the machine.

### Use of Extension Cords

While we strongly discourage the use of an extension cord with this machine, we understand that there may be situations where it is necessary and can only be used temporarily.

It’s important to note that extension cords can lead to voltage drop, which, in turn, can damage electrical

components and reduce the motor’s lifespan. The extent of voltage-drop increases with the length of the extension cord and decreases as the gauge size of the cord gets smaller (higher gauge numbers indicate smaller sizes).



If you find it necessary to use an extension cord with this machine, please adhere to the following guidelines:

1- Ensure the extension cord is in good condition and contains a ground wire, as well as a matching plug and receptacle.

2- Select an extension cord with a minimum gauge between 16AWG and 12 AWG. The wire gauge depends on the length of the extension (under 50’ 16AWG, under 100’ 14AWG, and finally, under 150’ 12AWG). **DO NOT exceed 150’ length.**

3- Keep the length of the extension cord as short as possible. A shorter cord is preferable to minimize voltage drop.

By following these guidelines, you can help mitigate the potential negative effects of using an extension cord and maintain the safety and performance of the machine when it becomes necessary to use one.

### Electric Motor Information

Power: 1.75HP

Class: B.

Voltage: 120V.

Hertz: 60Hz.

Phase: single.

Start Capacitor: 150 $\mu$ F-300VAC,  
Measurements: 1-11/16”X3-1/8”.

Poles: 2 poles.

Run Capacitor: 50 $\mu$ F-450VAC  
measurements: 2”X3-11/16”.

Plug: JT3.

Cord: SJT3/C 14AWG.



## Section 3: Unpacking and Assembly

### Unpacking, Inventory, and Initial Cleanup

1. Upon receipt, carefully unpack all contents from the shipping carton and verify against the provided list to ensure completeness. Please see the packing list in the hardware and tool packing list section below. Handle parts delicately, placing them on a protected surface for identification and assembly. In the event of missing or damaged components, promptly contact our customer service department for assistance see contact information above on page 3. Avoid operating the machine if any components are absent to prevent potential injury or damage.

2. Document any observed shipping damage and promptly inform your local Busy Bee Tools. Capture photographic evidence to support potential insurance claims.

3. With assistance, lift the Bandsaw from its packaging and position it on a level surface.

4. Remove any rust protection coatings from surfaces using a household-type grease or spot remover. Avoid using harsh substances such as gasoline, paint thinner, or mineral spirits, as they may harm painted surfaces.

5. Apply a protective coat of paste wax to the table to inhibit rust formation. Ensure thorough cleaning of all components with a dry cloth, taking care to avoid contact with the sharp teeth of the pre-installed bandsaw blade to prevent injury.

6. Store packing materials and the shipping carton in a designated area until the machine is fully assembled and operational. Do not dispose of these materials prematurely.

#### Tools needed.

When setting up the woodworking bandsaw, ensure you have all necessary tools readily available. While the machine typically comes equipped with essential tools, including wrenches and blade adjustment tools, it's essential to have a level and a 90° angle on hand for precise machine alignment. Use the level to ensure the machine's base is flat and stable, minimizing the risk of vibration and instability during operation. Additionally, employ the 90° angle to accurately adjust the saw's blade and table to ensure perpendicular cuts. By using these tools in your setup process, you enhance the accuracy and safety of the woodworking bandsaw, promoting efficient and reliable operation.

### Unboxing and Initial Cleanup of your Band Saw



Figure 3: Unboxing the Band Saw.

Carefully remove all contents from the shipping carton.

1- Compare the contents with the provided list to ensure all items are accounted for before discarding any packing material.

2- Place parts on a protected surface for easy identification and assembly.

3- If any parts are missing or broken, contact Busy Bee Tools Customer Service for replacements of the damaged parts. Do not turn on the machine if any items are missing to avoid injury or damage.

#### Shipping Damage

Report any shipping damage to your local Busy Bee Tools.

Take photographs of the damage for any potential insurance claims. Send all the photographs taken to Busy Bee Tools Customer Service department.

#### Cleaning

Clean all rust-protected surfaces using ordinary household grease or spot remover. Avoid using gasoline, paint thinner, mineral spirits, or similar substances as they may damage painted surfaces.



### Retaining Packaging Materials

Set packing material and the shipping carton aside. Do not discard them until the machine has been completely set up and is operating correctly.

These steps will ensure a safe and effective setup of your bandsaw, preventing damage to the machine and injury to the operator.

### Hardware and Tools Packing List

Once you open the package the first thing you must do is inventory all the accessories and parts inside the package. If any part or hardware is missing please contact Busy Bee Tools for replacement parts. See figure 4.

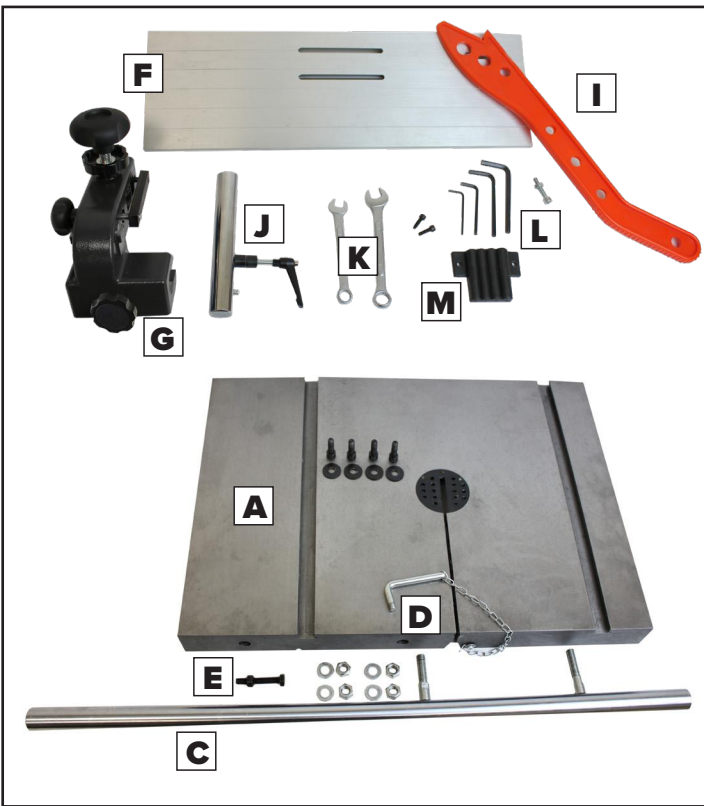

Figure 4: The Table, Fence, Tools and Accessories.

### Table Assembly:

- A- Table and bolts and washers.
- B- 90° table leveling stop bolt (not shown).
- C- Rip fence front rail.
- D- Table leveling lock and lanyard.
- E- Rail's mounting nuts and washers.

### Rip Fence Assembly:

- F- Rip Fence.
- G- Rip Fence Carriage Assembly.
- H- Guidepost Cap (not shown).

- I- Push Stick and its mounting bolt and nut.
- J- Resaw Bar Assembly.

### Tools and Tool Holder:

- K- Wrenches 10 and 13mm.
- L- Allen Keys 3, 4, 5, and 6 mm.
- M- Allen Key Holder and Mounting Screws



### Assembly Instructions:

**THE MACHINE MUST NOT BE PLUGGED IN AND THE POWER SWITCH MUST BE IN THE OFF POSITION UNTIL ASSEMBLY IS COMPLETE. All the part numbers referred to in the installation section can be found in the machine's diagrams section**

### Setting Up and Positioning the Bandsaw

The bandsaw is heavy, weighing over 210 lbs, so it's best to assemble it near its final location. Follow these steps to ensure a safe and proper setup:

### Handling and Moving:

- 1- When moving or positioning the assembled bandsaw, do not use the table or upper blade guard assemblies to lift the machine, as this can cause damage.
- 2- Move the bandsaw by grasping the support column and lower frame, which are welded together for rigidity.
- 3- Alternatively, lay the bandsaw down on the back/left side of the column to protect the table assembly.
- 4- Do not install casters onto the stand's legs, as this will make the bandsaw unstable. Use a universal mobile base (available separately) that places the saw inside a wider wheelbase frame for stable movement.

### Unpacking:

- Carefully remove the machine from the shipping carton, following the handling instructions above.



Figure 5: Unpacking the Band Saw.

### Positioning:

1- Place the machine on a solid, level foundation in an area with ample space in front, on the right side, and behind the bandsaw to accommodate large or long material.

2- For optimal power and enhanced safety, plug the bandsaw directly into a dedicated, grounded electrical outlet within the reach of its original cord length. Using an extension cord is strongly discouraged.

### Workspace Considerations:

1- Align the machine so that the material being cut does not face aisles, doorways, or other work areas where bystanders may be present.

2- Avoid locating or using the machine in damp or wet conditions.

### Securing the Machine:

1- Once positioned in your shop, level the machine using spacers and secure it to the floor with lag screws (not supplied) through the 4 holes in the base stand legs.

2- Do not install casters using these holes, as this will damage the stand's bolt-down pads. These steps will ensure that your bandsaw is securely and safely positioned, providing a stable and efficient working environment.

### Table Assembly Instructions

**Remove the Leveling Pin:** Extract the Table Leveling Pin (Part #4B) from the front of the table. This pin ensures the two sides of the table remain level in the slot area Fig. 6.

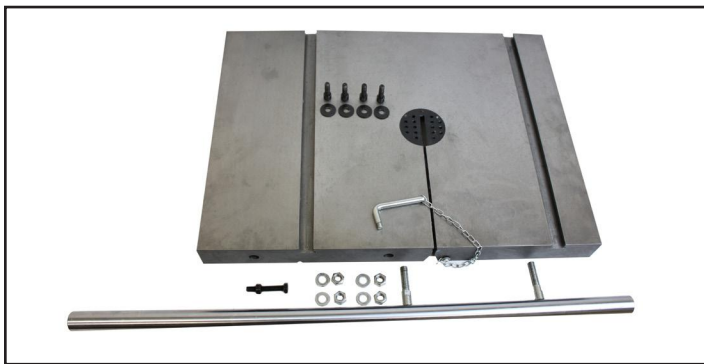

Figure 6: The Table and Leveling Pin.

**Mount the Table:** With assistance, mount the table onto the trunnion. The table is heavy, so approach this from the rear of the machine to easily fit the pre-installed blade through the slot in the table.

### Attach the Table:

1- Secure the table to the trunnion using four Hex Socket

Cap Screws, Spring Washers, and Washers (Parts #11B, 10B, 9B). Start by installing two bolts on the right side of the blade, hand-tightened only Fig. 7.

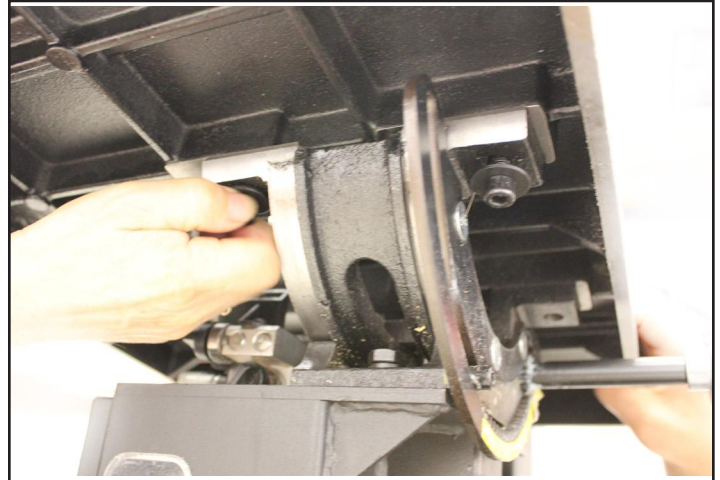

Figure 7: Installing the Table.

2- Tilt the table to a 45-degree angle and install the two bolts on the left side of the blade Fig.7. Do not fully tighten the bolts at this stage. Return the table to a horizontal position.

### Align the Table:

Before final tightening, ensure the table's miter gauge slot is parallel to the side of the saw blade for accurate cuts. Use a thin metal ruler set against the side of the saw blade, avoiding contact with the teeth. Measure the distance from one end of the ruler to the miter gauge slot, then repeat the measurement from the other end of the ruler to the slot. Fig.8. Adjust the table until both measurements are identical.

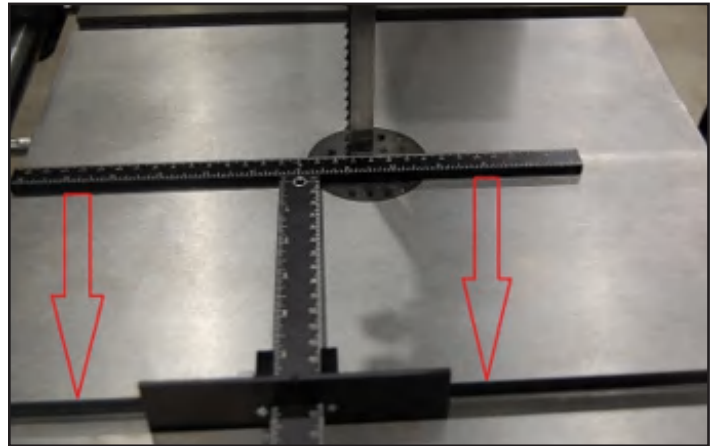

Figure 8: Aligning the Table with the Blade.

### Secure the Table

Once the table is aligned parallel to the blade, fully tighten all four bolts to secure the table in place. By following these steps, you will ensure the table is properly mounted and aligned for precise and safe operation.

### Installing the 90° Table Stop

1- Thread the Hex Bolt and Nut:

Insert the Hex Bolt into the pre-bored and tapped hole on the bottom of the table.

- Secure it in place by threading the Nut onto the bolt refer to Fig. 9.

2- Set the Table to 90°:

- The precise setting of the table to 90° relative to the blade will be completed later.

By installing the 90° table stop, you ensure accurate and repeatable alignment for perpendicular cuts.



Figure 9: Installing the 90-degree table stop.

### Install the Fence Support Bolt

1- Locate the pre-bored and tapped hole on the rear, left corner lip of the table.

2- Install the Fence Support Bolt and Nut in this hole.

3- When the fence is moved to the far left on the front rail, it will be off the table but supported by this bolt.

### Rip Fence Assembly

1- Mount the Fence Guide Rail

- Attach the Fence Guide Rail to the front edge of the table using the two Fence Bar Nuts and Washers Fig. 10.
- Ensure the rail is parallel to the table surface and equidistant from the front edge at both the left and right sides.

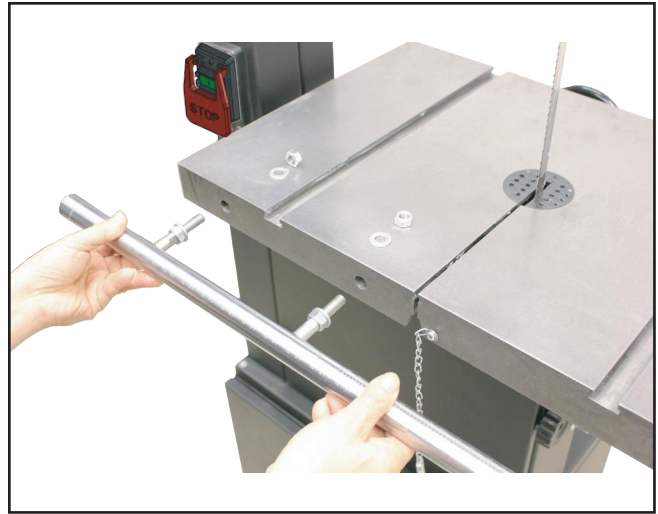

Figure 10: Installing the Fence Rails.

2- Slide the Fence Carrier and Fence Assembly

- Slide the Fence Carrier and Fence Assembly onto the Fence Guide Rail.

3- Lock the Fence Carrier

- Secure the Fence Carrier in place by tightening the Fence Lock Knob located on the front of the carrier see Fig.11.



Figure 11: Securing the Rip Fence.

4- Final Adjustments

- Refer to the next section for final adjustments to the fence.
- Information on the re-saw bar is provided in the NEXT section.

### Install the Hand Wheels

- 1- Attach the Handwheel for Blade Guard Adjustment
  - Use a 5mm hex wrench to attach the Handwheel to the upper right side of the saw frame. This wheel raises and lowers the blade guard see Fig. 12.



Figure 12: Installing Handwheel

- 2- Attach the Handwheel for Motor Drive Belt Tension
  - Use a 5mm hex wrench to attach the Handwheel to the lower right side of the frame. This wheel adjusts the motor drive belt tension. It is similar to Fig. 12.

- 3- Install the Blade Tension Handwheel
  - Install the Blade Tension Handwheel to the top of the saw frame. No tools are needed; the handwheel's metal shaft engages the Blade Tension Rod using two simple pins Fig. 12.

### Install the Tool Holder

- 1- Assemble the Tool Holder
  - Attach the Tool Holder to the rear of the column using two Phillips Screws see Fig. 13 for tool holder location.
  - This provides handy storage for the Hex Wrenches (3, 4, 5, and 6 mm).



Figure 13: Installing the tool and Push Stick Holders.

### Install the Push Stick Holder

- 1- Assemble the Push Stick Hanger Bolt and Nut
  - Use a 5mm hex wrench to attach the Push Stick Hanger Bolt and Nut to the left side of the column.
  - This provides convenient storage for the push stick when not in use see Fig. 13.

### Install the Guidepost Cap

- 1- Place the Guidepost Cap
  - Insert the Guidepost Cap into the square hole on top of the upper frame.
  - This cap serves to protect the guidepost assembly from shop dust or debris Fig. 14.



Figure 14: Installing Guidepost Cap.

### Dust Collection

The BBPBS14N band saw features a 4" dust port at the rear. The dust collection system must maintain a minimum suction of 650 CFM at this port. Accumulated dust must be cleared and removed daily.

### Adjustment Instructions

#### **⚠ WARNING**

**THE MACHINE MUST NOT BE PLUGGED IN AND THE POWER SWITCH MUST BE IN THE OFF POSITION UNTIL ASSEMBLY IS COMPLETE. NOTE THAT ALL PARTS NUMBERS CAN BE REFERENCED IN THE MACHINE'S DIAGRAMS AT THE END OF THIS MANUAL.**

### Tilting the Table

- 1- Loosen the Locking Handle
  - At the rear of the saw, turn the Locking Handle on the table trunnion counterclockwise to loosen it, see Fig. 15.

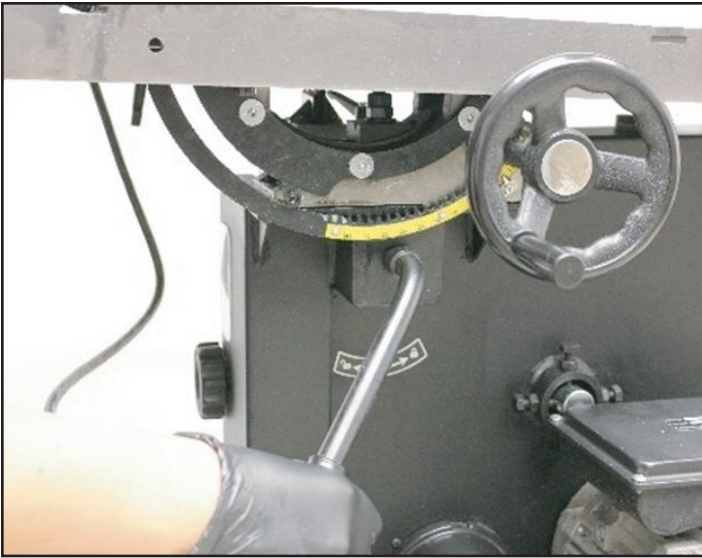

Figure 15: Adjusting the Table Tilt.

### 2- Adjust the Table Angle

- Use the Table Tilting Knob to adjust the table to the desired angle see Fig. 9 for the 90° stop bolt.
- Refer to the angle indicator scale cast into the Trunnion Bracket Support to set the desired angle.

### 3- Secure the Table

- Once the desired angle is achieved, tighten the Locking Handle to secure the table in place.

### Setting the Table Square to the Saw Blade's Side

To set the table at 90° to the saw blade sides, follow these steps:

#### 1- Loosen the Bolt's Locking Nut

- First, loosen the Locking Nut of the table stop bolt Fig. 9.

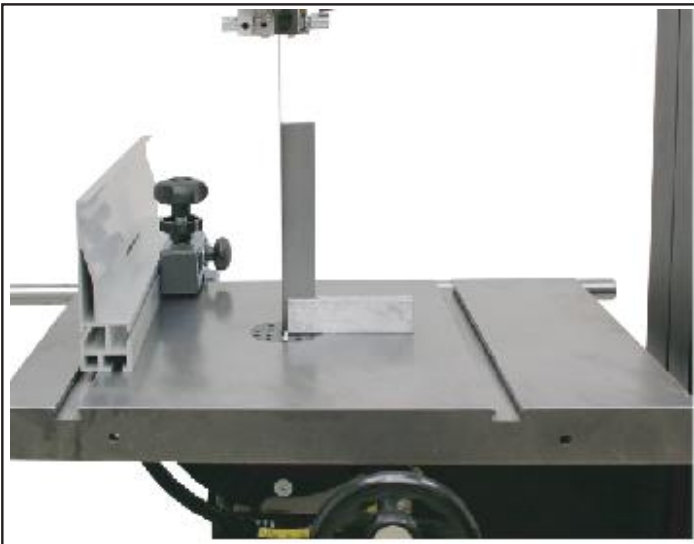

Figure 16: Squaring the Table to the Blade.

### 2- Square the Table

- Place a square on the table and against the saw blade's flat side.
- Tilt the table until it is precisely set at 90° to the blade, then lock the table in position.

### 3- Adjust the Bolt

- Adjust the bolt up or down until it contacts the pivoting Table Angle Stop Block see Figure 9
- Retighten the locking nut, ensuring the table angle setting is maintained.

### 4- Adjust the Angle Indicator

- The angle indicator on the trunnion can be adjusted by loosening the Phillips head screw and moving the pointer into position see figure 17.



Figure 17: adjusting the pointer position.

### Tracking the Saw Blade

Before proceeding, ensure the bandsaw is unplugged.

Follow these steps to check the blade tracking:



Figure 18: Tracking the blade.

#### 1- Prepare for Inspection

- Ensure both doors are open.
- Adjust the upper and lower blade guides away from the blade.
- Set the tension scale to match the width of

the blade being used.

### 2- Loosen the Lock Lever

- Located at the rear of the machine, turn the Lock Lever FIG.19. counterclockwise to loosen.



Figure 19: Blade Tracking mechanism.

### 3- Adjust Blade Tracking

- Turn the Blade Tracking Handle Fig. 19 clockwise or counterclockwise.
- Simultaneously, rotate the Upper Wheel by hand.
- Check the blade tracking on the wheel through the side window.
- Make at least three rotations of the wheel or until the blade tracks centered on the wheel.

### 4- Secure the Adjustment

- Once the blade runs centered, tighten the lock lever, and close the doors.

*Note: The lower wheel is pre-set at the factory. Any adjustments should be made after thorough reading and understanding of the instructions to avoid damaging the machine.*

## Adjusting the Blade Tension

### 1- Ensure Quick Release Lever is in the "ON" Position

- Always tension the blade with the Quick Release Lever in the "ON" position (Figure 16).
- Failure to do so may lead to inadequate blade tension or tension failure.

*Note: Release or turn the Quick Release Lever "OFF" only when changing the blade or when the saw is not in use for extended periods to prolong the blade's life.*

## 2- Adjust Blade Tension



Figure 20: The Blade Tensioning Handwheel.

- Use the Blade Tension Handwheel Fig. 20 located on the top of the saw.
- To increase tension, turn the handwheel clockwise.
- Tension the blade until the Tension Indicator Arrow Fig. 21 aligns with the width of the blade being used.
- View the indicator arrow through the front window of the top door.



Figure 21: The Blade Tensioning Indicator.

*Note: The blade tension scale may vary due to blade specifications such as steel thickness, material, or welded blade length variations. Adjust the tension arrow up or down one size on the scale to match your blade. Record the setting for future use of the same blade.*

### 3- General Rule for Blade Tension

- With the saw unplugged and the blade guard up, the blade should deflect about 1/4" when pressed with a finger to the side.
- Refer to page 19 for information on adjusting the Blade Tension Stop for blades welded slightly longer than the specified length of 111".



#### 4- Caution

- Excessive counterclockwise turning of the Blade Tension Handwheel to release tension may unscrew the threaded Blade Tension Rod from its tapped Block, Fig. 22.

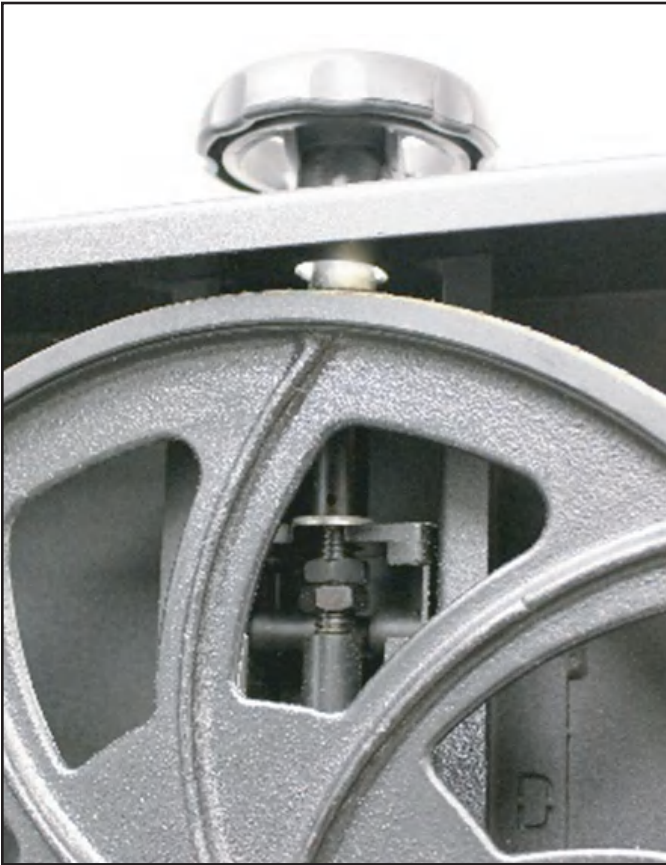

Figure 22: The Blade Tensioning Assembly.

- If this occurs, blade tensioning becomes impossible as the handwheel will freely turn. Re-thread the rod into the block to resume blade tensioning. **DO NOT TURN THE HANDWHEEL EXCESSIVELY.**

#### Adjusting the Blade Tension Stop

If you encounter difficulty setting full tension on a new blade, it's likely welded slightly longer than the standard 111" length, extending beyond the pre-set tensioning range of the saw. Follow these steps to adjust:

##### 1- Locate the Blade Tension Rod

- Behind the top bandsaw wheel, find the threaded Blade Tension Rod.

##### 2- Adjust the Nuts

- Loosen the Nuts on the Blade Tension Rod.
- Screw them upward by about 1/4".

##### 3- Retighten

- Once adjusted, retighten the Nuts.

This adjustment will increase the blade tensioning range of the saw to accommodate your new blade.

#### Changing the Bandsaw Blade

Follow these steps to safely change the bandsaw blade:

##### 1- Unplug the Machine

- Disconnect the machine from the electrical supply to prevent accidental activation.

##### 2- Open Wheel Doors

- Open both the top and bottom wheel doors.

##### 3- Release Blade Tension

- Move the Quick Release Lever from right to left to release the blade tension Fig. 9.

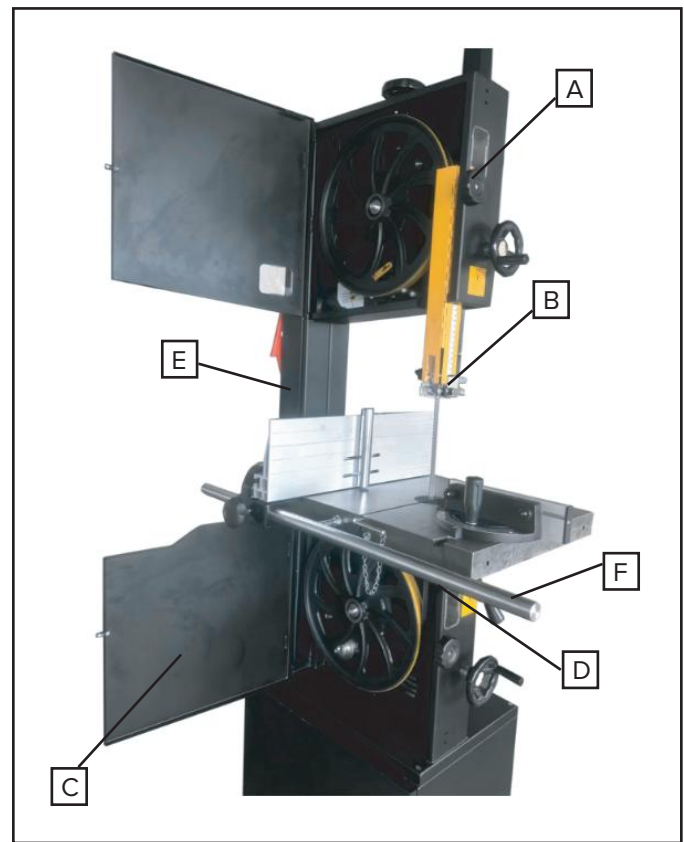

Figure 23: Replacing the Saw Blade.

##### 4- Open the Blade Guard Door

- Loosen the Locking Handle (A) and open the Hinged Door on the blade guard Fig. 23.

##### 5- Remove the Old Blade

- Remove the old blade from the top wheel.
- Feed it through the upper blade guides (B), slot in the table (C), lower blade guides (D), lower blade guard, slot in the column of the machine (E), off the bottom wheel, and around the front rail (F).
- Be cautious of sharp saw teeth and wear gloves for protection.

## 6- Install the New Blade

- Reverse the steps from 1 to 5 above when installing the new blade.
- Ensure the blade teeth are pointing downwards and towards you at the position where the blade passes through the table.

## 7- Center the Blade on Both Wheels

## 8- Re-Tension the New Blade

- Move the Quick Release Lever back to the ON position and check the blade tracking. The blade should run in the center of the wheels.
- Refer to “Tracking the Saw Blade” for detailed instructions.

## 9- Reset the Blade Guides

- Follow the instructions in the section “Adjusting the Blade Guides”.

## 10- Reset the Blade Tension

- Adjust the blade tension as described in the section “Adjusting the Blade Tension”

## 11- Close and Lock the Blade Guard Door

- Close the hinged door on the blade guard and tighten the locking handle to secure it closed.

## 12- Close and Lock Wheel Doors

- Close and lock both wheel doors before reconnecting the power supply.

To adjust the Blade Tension Indicator Arrow, Fig. 21, follow these steps:

1- With moderate tension on the blade, loosen the adjusting Screw (#14) on the Indicator Plate using a Phillips head screwdriver.

2- Adjust the blade indicator up or down as needed to align it properly, then tighten the adjusting screw to secure the plate in place.

If you encounter difficulty setting full tension on a new blade, it may be because the blade is welded slightly longer than the standard 111” length, extending beyond the pre-set tensioning range of the saw. To rectify Follow these steps to adjust the Blade Tension Stop:

1- Locate the threaded Blade Tension Rod behind the top bandsaw wheel Fig. 22.

2- Loosen the Nuts and screw them upward about 1/4”, then retighten. This action increases the blade tensioning range of the saw to accommodate the longer blade.

These adjustments ensure accurate blade tensioning and alignment, improving the performance and longevity of the bandsaw.

## Adjusting Blade Support Bearings & guides

To adjust the blade guides on the bandsaw with industrial, ball bearing guides, follow these steps:

### Upper guides

1- Begin by positioning the right and left guides relatively close to the blade. Loosen the front Screws (A) Fig 24. Use the knurled, micro-adjusting Knobs (B) Fig 24 to move the guides towards or away from the blade.

2- Ensure the front of the guides is approximately 1/16” behind the gullets of the saw blade (Fig. 24 ). If adjustment is needed, loosen the Locking handle (D) and adjust the upper guides until properly positioned. Retighten the Locking handle after adjustment.

3- Set both side-bearing guides to within 1/32” of the saw blade, roughly the thickness of a business card Fig. 24.

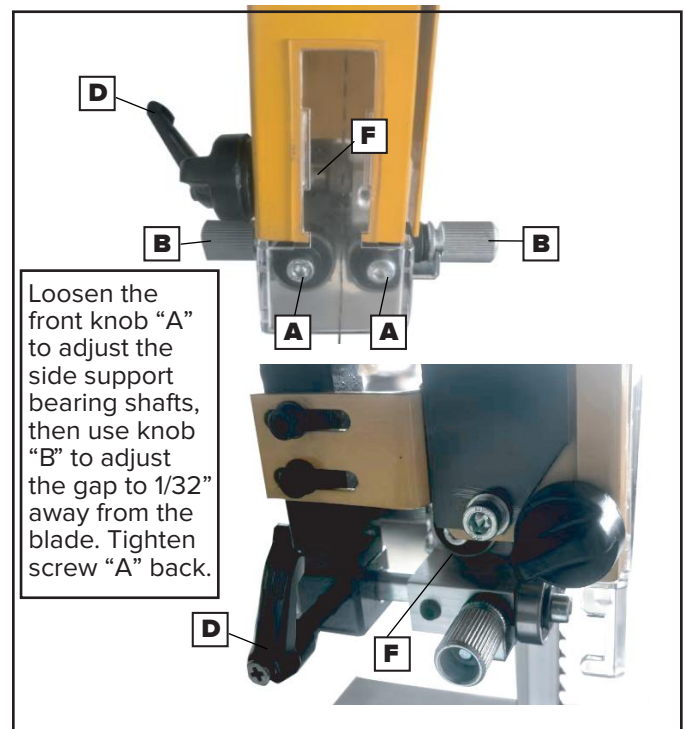

Figure 24: Upper Blade Guide Adjustment.

Avoid setting the bearing guides too close or touching the sides of the blade to prevent adverse effects on blade and bearing life.

4- Adjust the rear bearing guide to be just clear of the back of the saw blade. Loosen the rear guide’s Locking screw (F, Fig. 24) and move the rear guide towards the blade by turning the rear, knurled micro-adjusting Knob.



This action pushes the end of the guide's Long Shaft. Once correct adjustment is achieved, lock the guide in place by tightening the Locking screw.

### The Lower ball bearing guides

Located beneath the table follow a process similar to that of the upper guides. Here's how to do it:

1- Begin by loosening the lower support Locking Handle, Fig 25. Then, use the micro-adjusting Knob, Fig 25 to move the blade Guide Block, Fig 24 until both side bearing guides are approximately 1/16" behind the gullets of the bandsaw blade, referring to Fig. 25. Once in position, tighten the Locking Handle.

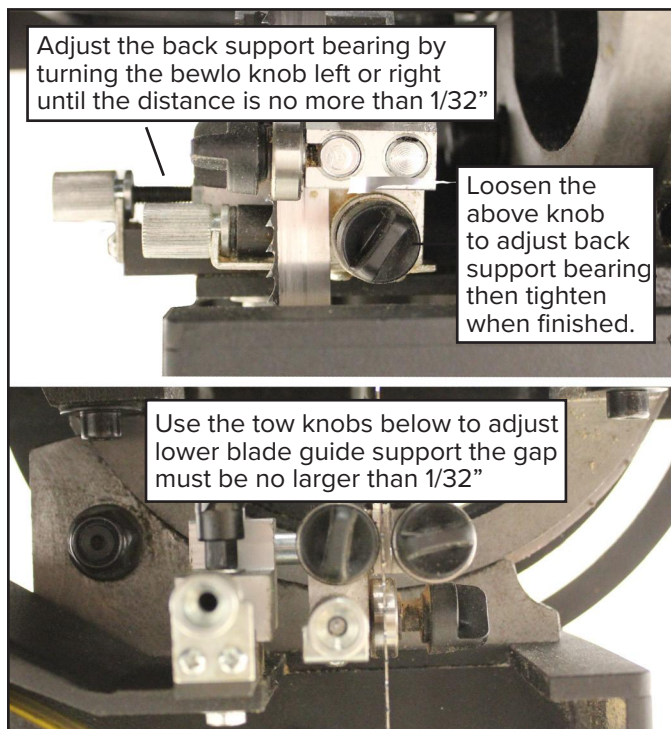

Figure 25: Lower Blade Guide Adjustment.

2- Set both side-bearing guides to within 1/16" of the saw blade, about the thickness of a business card. Avoid setting them too close or touching the blade's sides to prevent damage to the blade and bearings.

3- Loosen the front Locking Knobs Fig 25. Use these knobs as handles to slide the bearings towards or away from the blade. Once adjusted, secure the Locking Knobs.

4- Adjust the rear bearing guide to be just clear of the back of the saw blade. Loosen the rear guide's Locking Knob and use the lower, front micro-adjustment Knob Fig. 25 to move the rear guide towards the blade. When the correct adjustment is achieved, lock the guide in place by tightening the Locking Knob.

*Note: If the rear guide cannot be adjusted close to the rear of the blade (a potential issue with thin blades), adjust the blade's position on the wheel or move the lower Plate. There's a second position hole in the plate for the Hex Bolt. Unscrew the bolt and reposition it through the plate's other hole to readjust the guide's travel distance.*

*Note: Before commencing cutting operations, it's crucial to set the upper guide bearings approximately 1/4" above the top surface of the workpiece for optimal blade control*

### Setting Guide Assembly

1- Loosen the Guidepost Lock Knob (#23, Fig. 2) and adjust the Guidepost Handle (#10 Fig. 1) to raise or lower the guidepost/upper blade guide assembly to the desired height. A measurement scale provided on the right side of the guidepost facilitates quick reference for the guide bearings' height above the table surface.

2- Once the guide bearings are positioned correctly, securely tighten the guidepost lock knob. Note: The guidepost comes preset at the factory to align vertically with the bandsaw blade. If any slight adjustment is necessary:

3- Open the top door and lower the blade guard fully down to the table to access the Guide Bracket block.

4- Loosen the four Hex Bolts (C, Fig. 26 ) situated at the rear of the top frame. This enables the guidepost to be shifted or angled slightly left or right for correction.

5- Utilize the four Set Screws (Fig. 26) located at the rear of the guide bracket near the corners for additional adjustments. These screws facilitate angling the guidepost towards the front or back of the table, or twisting it on an angle:

- Advancing the top two set screws angles the post towards the rear of the table.
- Advancing the bottom two set screws angles the post towards the front of the table.
- Adjusting the left or right screws angles the post to the right or left.

6- Once the post is adjusted vertically, tighten the four hex bolts that were loosened in step 4 securely.

### Blade Guide Adjustment Instructions

Setting the Upper Blade Guide: Before cutting, ensure the upper blade guide is positioned 1/4" above the workpiece for optimal control.

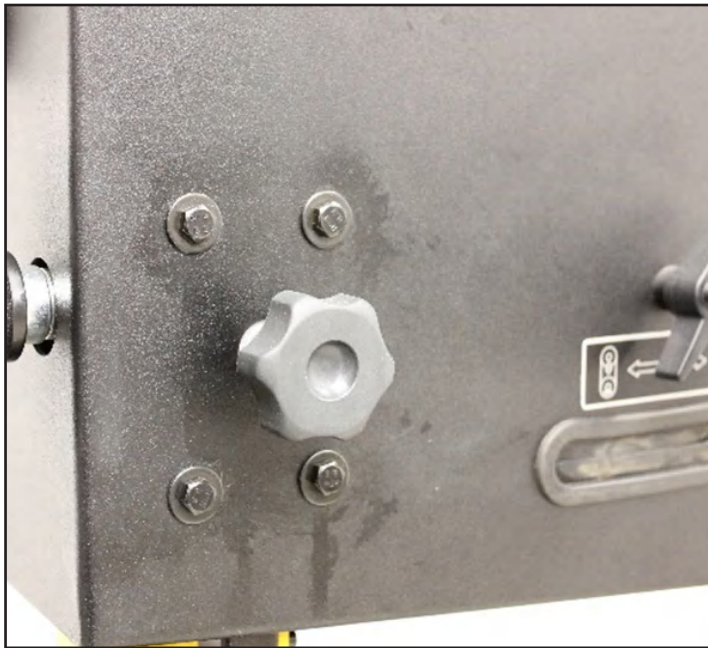

Figure 26: Adjusting the Blade Guidepost.

1- Loosen the guide's lock knob (the knob in between the 4 screws) as shown in Fig. 26.

2- Turn the guide handle (10) in Fig. 1 to raise or lower the blade guide assembly to the desired height. Note the measurement scale on the right-hand side of the guidepost.

3- Once the desired height is achieved, re-tighten the lock knob.

**NOTE:** The guidepost is pre-aligned with the blade at the factory. If adjustment is necessary, follow these steps:

#### Adjusting the Rip Fence for Drift

Bandsaw can be adjusted to eliminate drift, ensuring the fence is parallel to the blade. There are two methods to achieve this:

#### Method:

- 1- Loosen the lower fluted knob see step 1 fig. 27
- 2- Adjust the upper fluted knob to move the fence see step 2 figure 27.
- 3- Once you are satisfied with the position retighten the lower fluted knob.

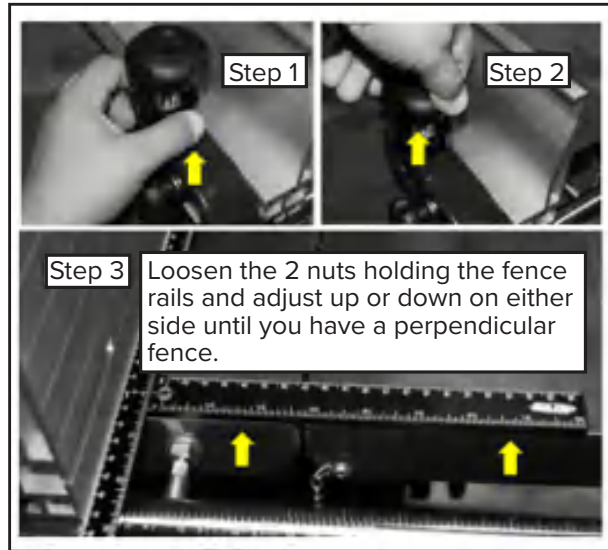

Figure 27: Fence Drift Adjustment

#### Adjusting the Fence to 90-Degrees

1. Use a square to check that the fence is 90 degrees to the table.
2. If adjustment is required, loosen the Fence Rail Nuts Fig. 28.

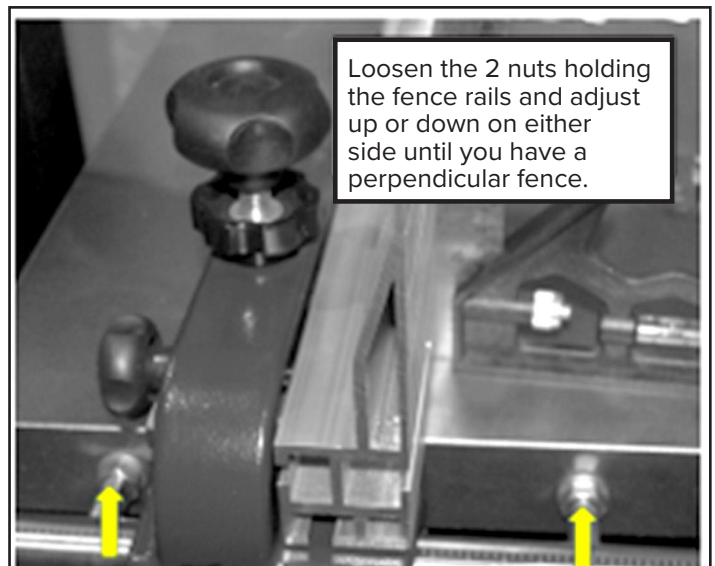

Figure 28: Fence Perpendicular Adjustment

3. Raise or lower either side of the fence's guide rail until the fence is at a 90-degree angle to the table.
4. Once aligned, fully tighten the Fence Rail Nuts Fig. 27.

#### Adjusting the Fence on the Carrier

The fence can be repositioned from vertical to horizontal or moved from the left side to the right side of the blade by adjusting the carrier's hardware and front rail.

### To change the fence from vertical to horizontal:

1. Loosen the fluted knob on the side of the carrier Fig. 29 that secures the Rip Fence to the Fence Carrier Fig. 29.



Figure 29: Changing the Fence to Horizontal

2. Slide the fence forward to remove it from the carrier's Sliding Block.
3. Remove the fence completely and lay it face down, there's a slot at the bottom of the fence where the bracket can slide.
4. Retighten the two Hex Screws to secure the fence in position on the carrier.
5. Check the fence for drift and make corrections if needed .

### Changing the Fence from the Left Side to the Right Side of the Blade

1. Remove the fence carrier with the fence from the front rail.
2. Mount the Fence Carrier onto the front rail on the right side of the blade.
3. Loosen the fence knob that secures the Rip Fence to the Fence Carrier.
4. Slide the fence forward to remove it from the carrier's Sliding Block .
5. Rotate the fence's knob and bracket 180° and reverse sides Fig. 29.
6. Slide the fence back on the bracket and tighten the knob

to secure the fence in position on the carrier step 3 Fig. 29.

7. Check the fence for drift and make corrections as needed according to the instructions on page ().

### Changing the Blade Speed

This bandsaw offers two blade speeds: high speed (2950 ft/min) and low speed (1445 ft/min). NOTE The bandsaw is shipped in high-speed mode.

The lower wheel features two integral "multi-vee" form pulleys, and the motor shaft has a twin multi-vee form pulley. The multi-vee belt runs around both the wheel pulley and the motor pulley. Belt tension is adjusted using the Handwheel.



Figure 30: Changing the Band Saw Speed.

### High Speed (3185 ft/min)\*

1. Install the belt on the rear pulley of both the motor and the wheel see Fig. 30.
2. High speed is suitable for general sawing needs of woods and composites.

### Low Speed (1510 ft/min):

1. Install the belt on the front pulley of both the motor and the wheel see Fig. 30.
2. Low speed is ideal for cutting hard materials such as wood, plastics, and non-ferrous metals.
3. Ensure you use the correct blade type for clean and effective cutting of these materials.

### Adjusting the Drive Belt Tension

1. Turn the lower Handwheel Fig. 30 to adjust the belt tension.
2. Aim for about 3/8" to 1/2" deflection in the multi-vee drive belt.
3. **DO NOT over-tension the belt, as excessive tension can damage the belt, pulleys, and motor see Fig. 30.**

## ON/OFF Switch

To Operate the Saw:

- 1- Press the top, round “ON” button fully to turn the saw on. You should hear a ‘click’ indicating the contact is made.
- 2- To turn the saw off, press the bottom red safety switch.



Figure 31: Main Switch Assembly.

### Extended Periods of Inactivity:

- If the saw will not be used for an extended period, unplug it from the power supply and release the tension on the blade.

## Section 4: Operations

### Overview:

This overview serves as a foundational introduction for novice machine operators, offering a fundamental understanding of how the machine is used during operation. The goal is to facilitate a clearer comprehension of the machine’s controls and components discussed in subsequent sections of this manual.

It is important to note that this overview is generic in nature and does not constitute a comprehensive instructional guide. To gain a more in-depth understanding of specific machine operations, it is strongly advised to:

- 1- Read the Entire Manual: Thoroughly review the entirety of this manual to gain detailed insights into the machine’s operation, safety guidelines, and maintenance procedures.
- 2- Seek Additional Training: Seek guidance and training

from experienced machine operators who can provide hands-on instruction and insights into practical operation.

- 3- Conduct Additional Research: Expand your knowledge by conducting further research through “how-to” books, trade magazines, and reputable websites dedicated to the subject matter.

By following these steps, you can develop a well-rounded understanding of the machine’s operation and safety protocols, ensuring both your safety and the effective use of the equipment.

### Typical Machine Operation Procedure

To successfully complete a typical machine operation, operators should follow a systematic set of steps to ensure safety and accurate cutting. Here is a sequence of actions commonly employed:

- 1- Workpiece Examination: Examine the workpiece to verify its suitability for cutting, considering factors such as material type, foreign objects, knots, moisture content, and warping.
- 2- Ensure that you are using the appropriate blade type and TPI for the intended cut.
- 3- Table Tilt Adjustment: If necessary, adjust the table tilt to achieve the desired cutting angle.
- 4- Fence or Miter Gauge Setup: Depending on the cutting requirements, set up and adjust the fence for the width of the cut, or configure the miter gauge to the desired angle. Ensure that the fence or miter gauge is securely locked in place.
- 5- Upper Blade Guide Height: Loosen the guidepost lock knob and adjust the upper blade guide height to provide clearance, typically no more than 1/4”, just above the workpiece. Retighten the guidepost lock knob.
- 6- Clear Workpiece Path: Confirm that the workpiece can safely pass through the blade without encountering any obstructions or interference from other objects.
- 7- Safety Gear Preparation: Prior to operation, put on safety glasses and a respirator if necessary, especially when cutting materials that produce fine dust.
- 8- Machine Startup: Begin by starting the dust collector to manage dust and then activate the bandsaw itself.
- 9- Workpiece Handling: Hold the workpiece securely and keep it flat against both the table and the fence (or miter gauge). Gradually push the workpiece into the blade at a



consistent and controlled rate until the cut is completed. Be cautious to keep fingers away from the blade and use a push stick when handling narrow workpieces.

10- Shutdown: After completing the cut, stop the bandsaw.

Adhering to this procedure ensures a safe and efficient machine operation, minimizing the risk of accidents and producing accurate cuts. Always prioritize safety and precision when working with machinery.

### **Basic Functions of a Bandsaw**

A properly adjusted bandsaw is a versatile and safe tool that can perform a variety of cuts with precision. It excels in the following types of cuts:

**Straight Cuts:** Bandsaws can make accurate and straight cuts with ease.

**Miters:** It can be adjusted to cut at different miter angles.

**Angles:** Bandsaws can cut at various angles to accommodate specific project requirements.

**Compound Angles:** Complex angled cuts can be achieved using the bandsaw.

**Resawing:** Resawing involves cutting a thick workpiece into thinner sections, which a bandsaw can accomplish effectively.

**Ripping:** Bandsaws can rip boards, meaning they can cut along the length of the wood grain.

**Crosscutting:** This refers to cutting wood across the grain, and bandsaws can handle this task.

**Irregular Cuts:** Bandsaws are excellent for cutting irregular shapes, curves, duplicate parts, circles, and beveled curves.

### **Basic Cutting Tips**

Here are some fundamental tips to keep in mind when operating a bandsaw:

1- **Blade Maintenance:** Regularly replace, sharpen, and clean the blades to maintain optimal performance. Periodically check and adjust the guides, tension, and alignment settings to ensure the bandsaw operates smoothly.

2- **Even Pressure:** Use light and consistent pressure when cutting. Applying excessive force can lead to poor cuts and place undue stress on the bandsaw and blade.

3- **Corner Cutting:** When cutting around tight corners, avoid twisting the blade. Instead, allow the blade to naturally follow the corner's path. Consider using relief cuts when feasible to facilitate smoother cutting.

4- **Safe Techniques:** Always follow safe operating techniques. Misusing the bandsaw or employing incorrect techniques, such as twisting the blade or using the wrong feed rate, can compromise safety and result in subpar cuts.

By following these basic tips and understanding the versatility of a bandsaw, operators can utilize this tool effectively and achieve precise cutting results while ensuring safety throughout the cutting process.

### **Inspecting the workpiece**

Before initiating any cutting operations, it is essential to thoroughly inspect all workpieces to ensure both the safety of the operator and the proper functioning of the machine. Here are key considerations when inspecting workpieces:

1- **Material Type:** This machine is specifically designed for cutting natural and man-made wood products, including laminate-covered wood products and certain plastics. It is not suitable for cutting materials such as metal, glass, stone, or tile. Attempting to cut these materials with a bandsaw can lead to injury.

2- **Foreign Objects:** Prior to cutting, carefully examine workpieces for any embedded foreign objects, such as nails, staples, rocks, or dirt. These objects can become dislodged during cutting, potentially causing harm to the operator, kickback, or blade damage. If such objects cannot be removed, refrain from cutting the workpiece.

3- **Large/Loose Knots:** Be cautious of workpieces with large or loose knots. These can be dislodged during cutting, potentially leading to kickback or machine damage. Choose workpieces that do not have such knots or plan your cuts to avoid them.

4- **Wet or "Green" Stock:** Avoid cutting wood with a moisture content exceeding 20%. Cutting wet or "green" stock can result in premature blade wear, increased risk of kickback, and suboptimal cutting results.

5- **Excessive Warping:** Workpieces exhibiting significant cupping, bowing, or twisting are hazardous to cut, as they are unstable and unpredictable during cutting. Do not use workpieces with these characteristics.

6- **Minor Warping:** Workpieces with slight cupping can be safely cut if the cupped side is placed against the table or fence for support. Conversely, placing a workpiece with a



bowed side against the table can cause instability during the cut, potentially resulting in kickback or serious injury.

Adhering to these workpiece inspection and safety guidelines is vital to ensure a safe and productive cutting environment while using the bandsaw machine. For further information and a wide selection of products.

**Blade Selection & selection Chart**

**Selecting the appropriate width:**

Blade width is determined from the tip of the teeth to the rear edge of the blade. Adhere closely to the machine’s guidelines concerning recommended blade width selection.

For cut-off sawing operations, utilize the widest blade permissible by the machine. A broader blade facilitates straighter cuts and enhances feed speed.

For contour-cutting applications, strike a balance between maximizing width while ensuring the blade remains sufficiently narrow to achieve the desired radius. Refer to the accompanying figure for specific blade-to-radius requirements.

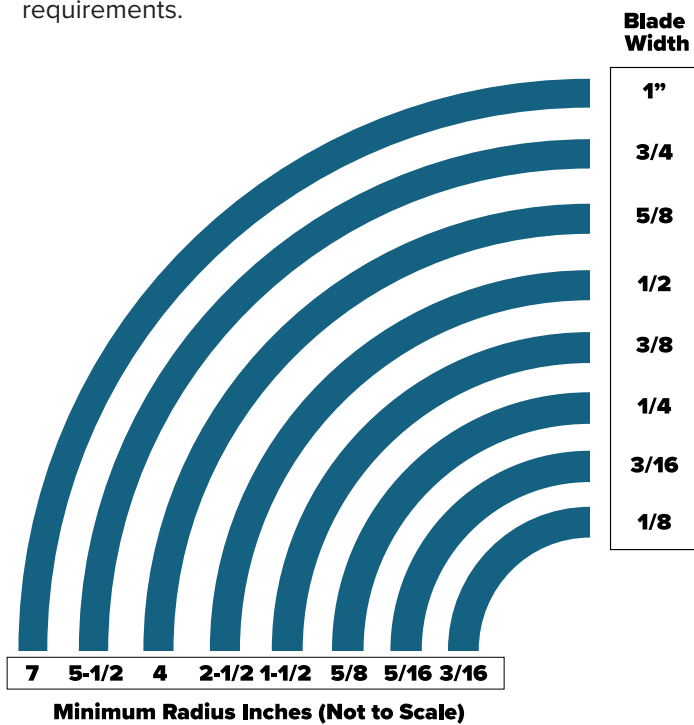

Figure 32: Blade Width to Radius of cut recommendations.

The number of teeth per inch (TPI) plays a crucial role in achieving the desired surface quality and feed rate. Coarse-toothed blades (2, 3 TPI) are highly effective for wood resawing and cutting materials up to 8 inches thick, whereas fine-toothed blades (18, 32 TPI) are suitable for thinner materials and plastics under 1/4 inch thick. For general cutting of 3/4 inch wood, a 4 TPI blade enables rapid cutting with a rough finish, while a 14 TPI blade facilitates slower cuts but yields a smoother finish.

When selecting the appropriate TPI, consider the following:

- Higher TPI results in a smoother finish but slower cutting.
- Lower TPI produces a rougher finish but faster cutting.
- Ensure at least 3 teeth are engaged in the material during cutting for optimal performance.

TPI	Min. Material Thickness
32	3/32"
24	1/8"
18	5/32"
14	1/4"
10	5/16"
8	3/8"
6	1/2"
4	3/4"
3	1"
2	1-1/2"

Figure 33: Workpiece Thickness and TPI relationship.

Understanding the Surface Feet per Minute (SFM) for different saw speeds is crucial for selecting the appropriate cutting speed for various materials. Refer to page () for detailed information. To calculate SFM, follow these steps:

1. Determine the RPM: Consult the machine datasheet in the manual for this information.
  2. Measure the diameter of the drive wheel in inches, then multiply by 0.262 to obtain the wheel circumference in feet.
    - Multiply the RPM by the wheel circumference to obtain the surface speed of the blade (SFM).
- Additionally, it’s important to note the following SFM guidelines:
- Spring steel wood cutting blades should not exceed 3000 SFM.
  - Carbon hard edge flexible back blades may be operated at up to 8000 SFM.

**Blade Care, Break-in, and Breakage**

Caring for a wood band saw blade entails a multifaceted approach to ensure its longevity and performance. Begin by thoroughly cleaning the blade after each use to remove sawdust and debris, preventing buildup that can compromise cutting efficiency. Regularly inspect the blade for signs of wear, such as dullness or damage, and replace it as needed to maintain optimal cutting performance. When

installing a new blade, it's crucial to properly break it in to minimize stress and prevent premature failure. To break in the blade, run it at a reduced speed for the first few minutes of operation, gradually increasing the speed to full capacity while periodically checking for any abnormalities. Additionally, to prevent blade breakage, ensure proper tensioning of the blade according to the manufacturer's guidelines, as both under-tensioning and over-tensioning can lead to stress and potential failure. The use of adequate blade lubrication such as wax or other blade treatment products during operation is also essential to reduce friction and heat buildup, mitigating the risk of breakage. By adhering to these practices, woodworkers can effectively care for their band saw blades, prolonging their lifespan and optimizing cutting performance.

### Changing Speed

To optimize the performance of the bandsaw, it's important to understand and utilize its two-speed capabilities effectively. By default, the bandsaw is shipped in high-speed mode, operating at 2950 ft/min. This setting is suitable for general woodworking tasks and cutting composite materials. The configuration for high speed involves placing the belt on the rear pulley of both the motor and the wheel, as indicated in Fig. 30 of the manual. For specialized cutting needs, such as working with extra hard materials like wood, plastics, and non-ferrous metals, the bandsaw offers a low-speed option operating at 1445 ft/min. To engage the low-speed setting, shift the belt to the front pulleys of both the motor and the wheel, following the instructions provided in Fig. 30. It's essential to choose the appropriate blade type for clean and effective cutting action when working with materials in low-speed mode. Proper blade selection ensures optimal performance and extends the lifespan of the bandsaw equipment.

### Tilting table

The bandsaw table offers a versatile range of tilt adjustments to accommodate various cutting needs. It can be tilted within the following range:

**5° Left to 45° Right:** To facilitate easy and precise adjustments, the bandsaw is equipped with the following features:

**Table Tilt Scale:** The trunnion features a scale with a pointer that allows operators to set and monitor the desired table tilt angle accurately.

**Positive Stop:** A positive stop is integrated into the design, enabling users to return the table quickly and conveniently to its 0° position when transitioning from a right-tilt setting. This feature simplifies the process of setting the table for different cutting angles, enhancing efficiency and accuracy

during operations.

To adjust the table tilt angle on the bandsaw, follow these steps carefully:

**1- Disconnect Machine from Power:** Prior to making any adjustments, ensure the machine is completely disconnected from its power source to guarantee safety during the procedure.

**2- Loosen Table Tilt Lock Lever:** Locate the table tilt lock lever see Figure 15. Loosen this lever to allow for table movement.

**3- Rotate Table Tilt Adjustment Lever:** Using the table tilt adjustment lever, carefully rotate the table to the desired angle. Ensure that the table is positioned accurately to match the angle required for your specific cutting task.

**4- Retighten Lock Lever:** Once the table is set to the desired angle, securely retighten the table tilt lock lever. This step is crucial to lock the table in place and prevent any unintended movement during operation.

By following these steps, you can effectively adjust the table tilt angle on the bandsaw, allowing you to make precise beveled cuts as needed for your woodworking projects. Always prioritize safety and proper adjustment when operating the machine.

### Ripping

Ripping on a bandsaw refers to cutting wood stock along the grain or down the length of the workpiece. This process is straightforward and can also be adapted for beveled rip cuts by tilting the table. Here's how to perform a rip cut on a bandsaw:

**1- Fence Adjustment:** Begin by adjusting the fence to match the width of the cut required for your workpiece. Once set, securely lock the fence in place to maintain the desired width throughout the cut.

**2- Blade Guide Height:** Adjust the blade guide assembly to the appropriate height above the workpiece. This ensures that the blade is positioned correctly for the cut you intend to make.

**3- Safety Precautions:** Prior to starting the bandsaw, ensure that all safety precautions have been met. This includes wearing appropriate safety gear, such as safety glasses and hearing protection. Verify that the workpiece is properly positioned and secured for the cut.

**4- Machine Startup:** Turn the bandsaw ON and wait for it to



reach full speed. It's important to allow the blade to achieve full speed before beginning the cut.

5- Feed the Workpiece: With all safety measures in place, slowly and steadily feed the workpiece into the blade. Continue to push the workpiece until the blade has completely passed through it.



Figure 34: provides an example of a ripping operation, illustrating how the bandsaw is used for this task.

By following these steps, you can safely and accurately perform a rip cut on your bandsaw, whether it's a straight rip cut or a beveled rip cut achieved by tilting the table. Always prioritize safety and precision during the cutting process.

### Crosscutting

Crosscutting on a bandsaw involves cutting wood stock across the grain or, in the case of plywood and other processed wood, cutting across the width of the material. These crosscuts can be made at 90° angles or at various angles using the miter gauge. Compound crosscuts are those where both the miter gauge is angled, and the table is tilted. Here's how to make a crosscut on a bandsaw:

1- Marking the Workpiece: Begin by marking the workpiece on the edge where you want to start the cut. This mark will serve as a reference point for lining up the cut.

2- Blade Guide Height: Adjust the blade guide assembly to the correct height above the workpiece. This ensures that the blade is positioned correctly for the crosscut.

3- Miter Gauge Angle: Adjust the miter gauge to the desired angle needed for the cut. This step allows you to achieve crosscuts at specific angles, whether they are 90° or angled cuts.

4- Positioning the Workpiece: Move the fence out of the way if not in use. Place the workpiece evenly against the miter gauge, aligning the marked reference point with the blade.

5- Safety Precautions: Before starting the bandsaw, ensure that all safety precautions are in place. This includes wearing safety gear like safety glasses and hearing protection. Verify that the workpiece is properly positioned and secured for the cut.

6- Machine Startup: Turn the bandsaw ON and allow it to reach full speed before proceeding.

7- Feed the Workpiece: With the safety measures in place, slowly and steadily feed the workpiece into the blade. Continue to advance the workpiece until the blade has completely cut through it.

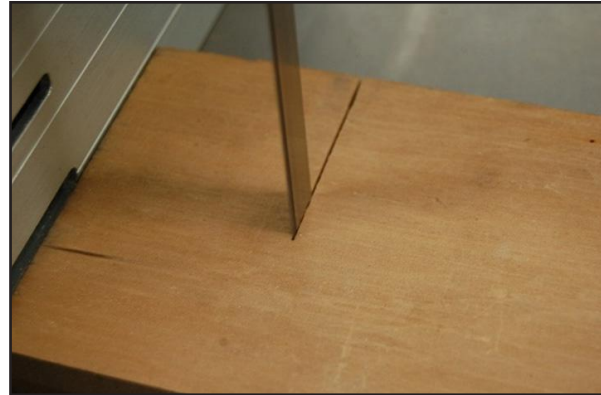

Figure 35: provides an example of a crosscutting operation, illustrating how the bandsaw is used for this purpose.

By following these steps, you can safely and accurately perform crosscuts on your bandsaw, whether they are straight crosscuts at 90° or angled crosscuts using the miter gauge. Always prioritize safety and precision during the cutting process.

### Cutting Curves

Cutting curves on a bandsaw requires a careful and precise technique to ensure the blade follows the desired layout line without twisting or binding. Here are the steps and tips to follow when cutting curves on a bandsaw:

1- Choose the Right Blade: Select a blade that is appropriate for the curve you intend to cut. For sharp or tight curves, use a narrower blade with a higher TPI (teeth per inch). This type of blade allows for more intricate and precise cuts.

2- Layout Line: Mark the layout line on your workpiece to guide the cut. This line represents the desired shape of the curve.

3- Relief Cuts: For sharp or tight curves, consider making relief cuts. Relief cuts are shortcuts made through the waste portion of the workpiece. These cuts are stopped at the layout line. Relief cuts serve several purposes:

- They prevent the blade from being pinched or twisted during the cut.



- They release waste wood from the workpiece, reducing pressure on the back of the blade.
- They make it easier to back the workpiece out once the saw blade has come to a stop, if necessary.

4- Short Cuts First: Start by making shortcuts along the curve, gradually working your way along the layout line. This approach helps reduce the chances of the blade binding or twisting during the cut.

5- Turning the Stock: As you feed the workpiece into the blade, simultaneously turn the stock carefully to follow the layout line. Maintain a steady and controlled feed rate to ensure the blade accurately follows the curve.

6- Longer Cuts: After completing the shortcuts, proceed to the longer cuts along the layout line. By this point, the relief cuts should have alleviated pressure on the back of the blade, allowing for smoother and more controlled cutting.

7- Safety Precautions: Always prioritize safety when cutting curves on the bandsaw. Wear appropriate safety gear, such as safety glasses and hearing protection, and ensure the workpiece is securely positioned and supported.

By following these steps and using relief cuts as needed, you can achieve accurate and smooth curve cuts on your bandsaw. Proper technique and patience are essential for successful curve cutting operations.

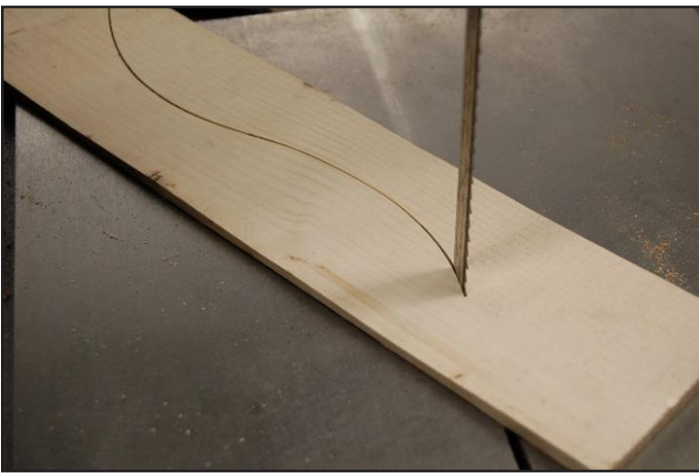

Figure 36: Cutting a curve.

By following these steps and using relief cuts as needed, you can achieve accurate and smooth curve cuts on your bandsaw. Proper technique and patience are essential for successful curve cutting operations.



Figure 37: Stacked Cutting.

## Resawing

Resawing on a bandsaw is the process of cutting the thickness of a board into two or more thinner boards. This technique allows you to maximize the use of your wood stock and create thinner boards for various projects. Here's how to perform resawing on a bandsaw effectively:

1- Blade Selection: The choice of the right blade is crucial for successful resawing. Opt for a wide blade as it cuts straighter and is less likely to exhibit "blade lead," which can result in uneven cuts. Blades with fewer teeth per inch (TPI) are ideal, typically ranging from 3 to 6 TPI. These blades have larger gullet capacities for clearing sawdust efficiently, reducing heat buildup and strain on the motor.

2- Prepare the Workpiece: Begin by selecting the board you want to resaw. Ensure that the board is flat and free of defects, as any irregularities can affect the quality of the resawn pieces. If needed, joint and plane the board to achieve a smooth, even surface.

3- Set Up the Bandsaw: Adjust the bandsaw's blade guide assembly to the proper height above the workpiece. The blade guide should be as close to the workpiece as necessary for stability but not so close that it causes unnecessary friction.

4- Blade Tension: Ensure that the bandsaw blade is properly tensioned. A well-tensioned blade will cut more accurately and reduce the risk of blade deflection during the cut.

5- Fence or Rip Fence: If your bandsaw has a fence or rip fence, set it to the desired width for the resaw cut. The fence helps maintain a straight cut by guiding the workpiece parallel to the blade.

6- Safety Gear: Prioritize safety by wearing safety glasses, hearing protection, and any other necessary safety equipment. Respiratory protection may also be required depending on the type of wood being cut.

7- Start the Bandsaw: Turn on the bandsaw and allow it to come to full speed before starting the cut. Always wait for the machine to reach its maximum speed to ensure a clean, efficient cut.

8- Resaw the Board: Carefully feed the workpiece into the blade, making sure it is flat against the table and the fence (if used). Maintain a steady and controlled feed rate to achieve an even cut. Keep your hands and fingers a safe distance from the blade.

9- Monitor the Cut: Pay close attention to the cut as it progresses. If you notice any deviations or irregularities in the cut, adjust as needed.

10- Complete the Cut: Once the entire length of the board has been resawn, turn off the bandsaw and wait for the blade to come to a complete stop before removing the resawn pieces.

11- Inspect and Plane: Examine the resawn pieces for any imperfections or rough surfaces. If necessary, use a planer to achieve a smooth, even thickness across the newly created boards.

Resawing on a bandsaw can significantly expand your woodworking capabilities and allow you to make the most of your lumber resources. With the right blade and proper technique, you can achieve precise and consistent results.



Figure 38: Resawing Process.

## Section 5: Accessories

This saw has an optional mobility kit BBPBMB14, sold separately. Busy Bee Tools offers a wide range of bandsaw blades for various types of cuts. Consult with our knowledgeable staff for assistance.

## Section 6: Maintenance

### Scheduling

Proper maintenance is essential to ensure the longevity and reliable performance of your bandsaw. Follow this maintenance schedule to keep your machine in top condition. Be sure to consult the specific maintenance instructions provided in your bandsaw's manual for any additional guidance or manufacturer recommendations.

### Daily Maintenance Check:

1- Loose Mounting Bolts: Inspect all mounting bolts and fasteners to ensure they are properly tightened. Pay particular attention to the bolts securing the table and fence.

2- Saw Blade: Examine the bandsaw blade for signs of wear, damage, or dullness. Replace the blade if it shows any visible defects or if it has become dull and less effective.

3- Wires: Inspect the electrical wires and cables for any wear, damage, or exposed wiring. Replace any damaged wires immediately to prevent electrical hazards.

4- Wheel Brush: Check the condition of the wheel brush, which is responsible for cleaning debris from the blade. Clean or replace the brush if it is worn or clogged.

5- Table Surface: Clean and protect the table surface. Ensure it is free from sawdust, debris, and any residue from cutting operations. Apply a suitable protectant to prevent corrosion.

6- Lubrication Points: Lubricate any specified lubrication points as recommended in your bandsaw's manual. Proper lubrication helps maintain smooth operation and prevents excessive wear.

7- General Safety Check: Inspect for any other unsafe conditions or anomalies that may affect the safe operation of the bandsaw. Address any identified issues promptly.

### Monthly Maintenance Check:

1- V-Belt Tension: Check the tension of the V-belt that drives the bandsaw. The belt should have the correct tension to ensure efficient power transmission. Adjust the tension if necessary and inspect the belt for damage or wear.

2- Dust Build-Up: Clean the interior of the bandsaw cabinet and the motor components. Remove accumulated sawdust and debris to prevent overheating and maintain optimal airflow.



*Regular and routine maintenance is crucial to the safe and efficient operation of your bandsaw. Following this schedule and addressing any issues promptly will help extend the lifespan of your machine and reduce the risk of breakdowns or accidents. Additionally, always refer to your bandsaw's specific manual for manufacturer-recommended maintenance practices and intervals*

### **Cleaning and protecting**

Cleaning your bandsaw is a straightforward process, and regular maintenance helps ensure its optimal performance and longevity. Here are the steps to clean your bandsaw:

#### **Cleaning the Bandsaw:**

1- Vacuum Excess Debris: Begin by using a vacuum cleaner equipped with a nozzle attachment to remove excess wood chips, sawdust, and debris from the bandsaw's interior. Pay close attention to areas around the blade, wheels, and motor housing.

2- Wipe Off Remaining Dust: After vacuuming, use a dry cloth or a dusting brush to wipe off any remaining dust and residue from the bandsaw's surfaces. Ensure that you remove dust from the table, fence, and other accessible areas.

3- Removing Resin Build-Up: If you notice any resin build-up on the bandsaw's components, use a resin-dissolving cleaner specifically designed for this purpose. Follow the manufacturer's instructions for safe and effective resin removal. Resin build-up can occur from cutting resinous woods, and it's essential to keep the blade and components clean for smooth operation.

4- Protecting Cast Iron Surfaces: To prevent rust on unpainted cast iron surfaces, such as the table, it's crucial to keep them dry and free from moisture. After cleaning, wipe down the cast iron surfaces with a cloth to remove any remaining moisture or wood dust. Periodically apply a rust-preventive product like

#### **Regular Maintenance Tips:**

1- Blade Maintenance: Regularly inspect the bandsaw blade for sharpness, wear, and damage. Replace the blade as needed to ensure clean and precise cuts.

2- Lubrication: Follow the manufacturer's recommendations for lubricating specific points on your bandsaw. Proper lubrication helps maintain smooth operation.

3- Belt Tension: Check and adjust the tension of the V-belt that drives the bandsaw according to the manufacturer's guidelines.

4- Safety Checks: Routinely inspect safety features, such as blade guards and safety switches, to ensure they are functioning correctly.

5- Blade Tracking: Monitor and adjust the blade tracking as necessary to ensure it runs smoothly and stays on the wheels.

6- Motor Cooling: Keep the motor and surrounding components free from dust and debris to prevent overheating.

By following these cleaning and maintenance steps, you'll keep your bandsaw in optimal condition, reducing the risk of breakdowns and ensuring safe and precise cutting operations. Always refer to your bandsaw's manual for specific maintenance instructions provided by the manufacturer. Maintaining the lower wheel brushes on your bandsaw is essential for preventing sawdust buildup on the tire and ensuring smooth operation. Here are the steps for checking and cleaning the lower wheel brushes:

#### **Wheel Brushes:**

##### **Daily Check and Cleaning of Lower Wheel Brushes:**

1- Inspect Brushes: Start by visually inspecting the lower wheel brushes to check for dirt, sawdust accumulation, and bristle wear. The brushes are designed to help keep the tire clean, so it's crucial to ensure they are in good condition.

2- Cleaning Brushes: If you notice that the brushes have accumulated sawdust or debris, use a stiff brush or a vacuum cleaner with a nozzle attachment to clean them. Brush away or vacuum the sawdust and dirt to ensure the brushes can continue to perform their function effectively.

3- Adjustment for Bristle Wear: As part of your daily inspection, check the adjustment brackets for the lower wheel brushes. These brackets allow you to adjust the brushes for bristle wear. If the bristles are significantly worn, consider adjusting the brushes to ensure they maintain proper contact with the tire.



## Adjusting Wheel Brushes for Bristle Wear

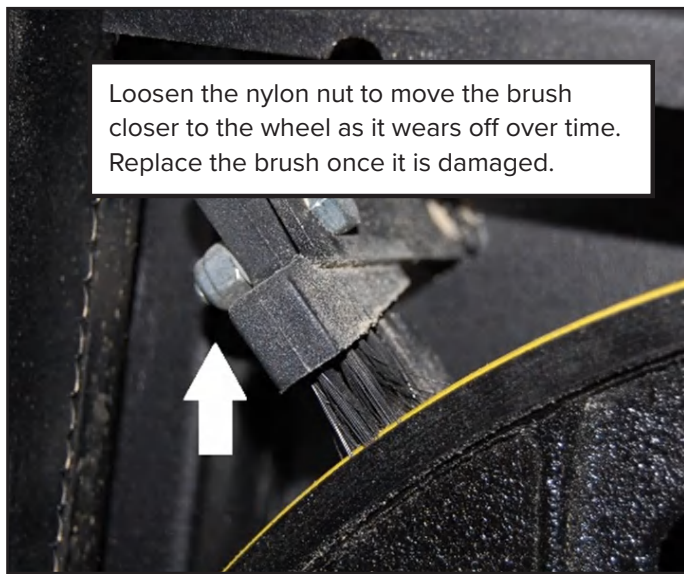

Figure 39: Brush Adjustment.

1- Disconnect Machine from Power: Ensure that the bandsaw is disconnected from the power source before making any adjustments or maintenance.

2- Access Adjustment Brackets: Locate the adjustment brackets for the lower wheel brushes. These brackets allow you to move the brushes closer to the tire as the bristles wear down.

3- Loosen Fasteners: Loosen the fasteners (usually screws or bolts) on the adjustment brackets. This will allow you to make the necessary adjustments.

4- Adjust Brush Position: Carefully adjust the position of the brushes so that they make proper contact with the tire. The goal is to ensure that the bristles touch the tire without excessive pressure.

5- Tighten Fasteners: Once you have made the adjustments, tighten the fasteners on the adjustment brackets securely but not overly tight. Ensure that the brushes are properly aligned with the tire.

6- Reconnect Power: After completing the adjustments, reconnect the bandsaw to the power source.

By regularly checking, cleaning, and adjusting the lower wheel brushes as needed, you'll help maintain the effectiveness of the tire cleaning system on your bandsaw. This simple maintenance task contributes to smoother and safer bandsaw operation. Always refer to your bandsaw's manual for specific instructions provided by the manufacturer.

## Lubrication

Proper cleaning and lubrication of your bandsaw components are essential for maintaining its performance and extending its lifespan. Here are the steps for cleaning and lubricating the components:

### Cleaning Components Before Lubrication:

1- Disconnect Machine from Power: Ensure that the bandsaw is disconnected from the power source before performing any maintenance or cleaning.

2- Identify Components: Identify the components that require cleaning and lubrication. These may include moving parts, sliding surfaces, and pivot points.

3- Use the Right Cleaner: Select an appropriate oil/grease, solvent, cleaner, or mineral spirit for cleaning the components. Make sure the cleaner is safe to use on the materials and paint of your bandsaw.

4- Apply Cleaner: Apply the cleaning solution to a clean cloth or rag. Do not apply it directly to the machine. Use the cloth to wipe down the components, removing any built-up dust, dirt, and grease. Pay special attention to areas where moving parts contact each other.

5- Thorough Cleaning: Continue wiping down the components until they are free from dirt and grime. You may need to use multiple clean cloths or rags to ensure thorough cleaning.

6- Inspect for Damage: While cleaning, inspect the components for any signs of damage, excessive wear, or corrosion. If you discover any damaged parts, they may require repair or replacement.

### Applying Lubrication:

1- Select Lubricant: Choose an appropriate lubricant for your bandsaw components. Follow the manufacturer's recommendations for the type of lubricant to use on specific parts. Common lubricants include oil or grease.

2- Apply Lubricant: Apply the selected lubricant to the cleaned components. Use a small brush, oiler, or a cloth to apply the lubricant precisely to the areas that require it. Avoid over-lubricating, as excess lubricant can attract dust and debris.

3- Operate the Machine: After lubricating the components, operate the bandsaw briefly to allow the lubricant to distribute evenly across the moving parts.

4- Wipe Off Excess: After the lubrication has been distributed, use a clean cloth to wipe off any excess



lubricant. This prevents the accumulation of dust and debris on the lubricated surfaces.

5- Reconnect Power: Once you have completed the cleaning and lubrication process, reconnect the bandsaw to the power source.

By following these steps, you can ensure that your bandsaw components are clean and properly lubricated, promoting smooth and safe operation. Regular maintenance and cleaning will help keep your bandsaw in excellent working condition. Always refer to your bandsaw's manual for specific lubrication recommendations provided by the manufacturer.

## Specific Maintenance for Band Saw

### Guidepost Rack

Lubricating the guidepost rack and pinion on your bandsaw is an important maintenance task to ensure smooth and precise adjustments. Here are the steps to lubricate the guidepost rack and pinion:

#### Lubricating Guidepost Rack and Pinion:

1- DISCONNECT MACHINE FROM POWER: Safety is a priority. Ensure the bandsaw is disconnected from the power source before starting any maintenance tasks.

2- Lower Guidepost: Lower the guide post all the way down. This will expose the rack and pinion components that require lubrication.

3- Prepare Cleaning Rag: Use a clean rag or cloth and mineral spirits to wipe off any existing grease and sawdust buildup on the rack and pinion components. Make sure to remove all dirt and debris to ensure proper lubrication.

4- Apply Lubricant: Once the components are clean, apply an appropriate lubricant to the rack and pinion. The lubricant should be specifically designed for this purpose and should not attract dust or debris. Follow the manufacturer's recommendations for the type of lubricant to use.

5- Distribute Lubricant: Move the guidepost up and down a few times to help distribute the lubricant evenly across the rack and pinion. This will ensure that the lubricant reaches all the contact points.

6- Wipe Off Excess: After distributing the lubricant, use a clean cloth to wipe off any excess lubricant. This step helps prevent the accumulation of dust and debris on the lubricated surfaces.

7- Reconnect Power: Once you have completed the lubrication process and wiped off any excess lubricant, you can safely reconnect the bandsaw to the power source.

**Regularly lubricating the guidepost rack and pinion will help maintain smooth and precise adjustments on your bandsaw. This contributes to the overall performance and longevity of the machine. Always follow the manufacturer's recommendations for lubricants and maintenance intervals provided in your bandsaw's manual for the best results.**

### Blade Tension Adjustment assembly

Lubricating the tension adjustment assembly on your bandsaw is essential to maintain its proper function and prolong its lifespan. Follow these steps to lubricate the tension adjustment assembly:

#### Lubricating Tension Adjustment Assembly:

1- DISCONNECT MACHINE FROM POWER: Prioritize safety by disconnecting the bandsaw from the power source to prevent any accidental start-ups.

2- Clean the Assembly: Use a clean rag or cloth and mineral spirits to thoroughly wipe off any existing grease and sawdust buildup from the blade tension adjustment assembly and tension lever cam (see Figure ). Ensure that these components are clean and free from debris.

3- Apply Lubricant: After cleaning, apply a thin coat of an appropriate lubricant to the cleaned areas of the blade tension adjustment assembly and the tension lever cam. Use a lubricant that is specifically designed for this purpose and recommended by the manufacturer. This will ensure smooth operation without attracting dust or debris.

4- Avoid Trunnions: Do not add lubricant to the cast iron trunnions (see Figure ), as these components produce their own fine graphite powder over time, acting as a natural lubricant. Adding additional lubricant to the trunnions may create a sticky substance that could impede smooth movement.

5- Close Upper Wheel Cover: After lubricating the necessary components, close the upper wheel cover. Ensure that it is securely fastened in place.

6- Reconnect Power: Once you have completed the lubrication process and closed the upper wheel cover, you can safely reconnect the bandsaw to the power source.

Regularly lubricating the tension adjustment assembly will help maintain precise tension control on your bandsaw, which is crucial for achieving accurate cuts. Always follow



the manufacturer's recommendations for lubricants and maintenance intervals provided in your bandsaw's manual for the best results.

## Section 7: Service

### Precautions Before you start:

Before cleaning or carrying out periodic service work, follow these precautions diligently:

1- Disconnect the Machine from the Power Source: Ensure the machine is disconnected from the power source (wall socket) before cleaning or maintenance. This prevents any accidental activation of the machine.

2- Avoid Using Water or Liquids: Never use water or other liquids to clean the machine. Instead, use a bench brush or a dry cloth to remove debris and dust.

3- Avoid Compressed Air Near Bearings: Do not use compressed air near bearings, as it may cause damage. Use caution when cleaning around these components. Simple vacuuming with a shop vac is sufficient.

4- Regular Maintenance is Essential: Performing regular maintenance on the machine helps prevent unnecessary problems and ensures optimal performance over time. Inspect all parts of the machine for any apparent damage or wear regularly and replace the damaged parts as soon as they are discovered.

5- When operating the band saw, make sure that it is connected to a dust collector providing 650CFM.

Following these precautions will help maintain the machine's functionality and prolong its lifespan.

### Check for Power Supply Issues:

- Ensure that the machine is properly connected to a functional power source.
- Verify that circuit breakers or fuses are not tripped or blown.

### Examine Blade and Blade Tension:

- Inspect the condition of the blade. Replace it if it's damaged, dull, or worn out.
- Check the blade tension to make sure it's correctly adjusted according to the manufacturer's guidelines.

### Verify Proper Blade Tracking:

- Ensure that the blade is correctly aligned on the wheels and that it is tracking properly. Misaligned or poorly tracked blades can lead to issues.

### Review Safety Features:

- Check if any safety mechanisms are engaged or malfunctioning. Ensure all safety guards, covers, and switches are in their correct positions.

### Inspect Table and Fence Alignment:

- Verify that the table and fence are correctly aligned to ensure accurate cuts.

### Check for Loose or Damaged Components:

- Inspect the machine for loose or damaged parts, such as bolts, nuts, or belts. Tighten or replace them as needed.

### Contact Technical Support:

- If you cannot identify or resolve the issue on your own, contact the manufacturer's technical support. Provide them with the serial number and manufacture date of your machine for assistance.

Remember to prioritize safety when troubleshooting and performing any maintenance or repairs on your machine. Always disconnect it from the power source before inspecting or adjusting. If you're unsure about a particular issue or procedure, it's best to seek professional assistance to avoid potential risks or damage to the machine.

## Section 8: Wiring and Electrical Diagram

### Wiring safety instruction

It is essential to take note of the manufacturer's advice regarding potential changes or updates to the electrical systems of your machine. Here are some key steps to follow if you suspect differences between your machine and the information provided in the manual:

1- Check the Manufacture Date: As mentioned in the manual, verify the manufacture date of your machine, which can be found on the main machine label.

2- Compare the Manual and Your Machine: Carefully compare the information and wiring diagrams provided in the manual with the actual components and wiring of your machine.

3- Contact Technical Support: If you identify any differences or have concerns about the electrical systems of your machine, reach out to the manufacturer's Technical Support team. They can provide guidance and updated wiring diagrams if necessary.

4- Provide Serial Number:\*\* Be prepared to provide the



serial number of your machine when contacting Technical Support. This information helps them identify the specific model and configuration of your machine.

5- Do Not Make Unauthorized Changes: As a precaution, avoid making any unauthorized changes or modifications to the wiring of your machine until you have received guidance from Technical Support.

6- Prioritize Safety: Always prioritize safety when dealing with electrical systems. Ensure that the machine is disconnected from the power source before inspecting or making any changes.

By following these steps and seeking assistance from Technical Support when needed, you can ensure that your machine operates safely and effectively, even if there have been updates or changes to its electrical systems since the manual was printed.

The warnings and guidelines provided in the manual are crucial for ensuring your safety and the proper functioning of your machine's electrical systems. Here's a summary of the key points to keep in mind:

1- Shock Hazard: Working on wiring connected to a power source can be extremely dangerous and may result in severe burns, electrocution, or even death. Always disconnect the power from the machine before servicing electrical components to prevent any electrical accidents.

2- Modifications: Avoid making unauthorized modifications to the wiring of your machine. Modifying the wiring beyond what is shown in the manufacturer's diagrams can lead to unpredictable and potentially hazardous results, including serious injury or fire. Additionally, the installation of unapproved aftermarket parts is discouraged.

3- Wire Connections: Ensure that all wire connections are tight and secure. Loose connections can pose a safety risk and may lead to electrical problems during machine operation. After any wiring task, double-check all connections to confirm they are properly tightened.

4- Circuit Requirements: Adhere to the circuit requirements outlined at the beginning of the manual when connecting your machine to a power source. This includes using the appropriate voltage, phase, and circuit amperage to ensure safe and reliable operation.

5- Wire/Component Damage: Damaged wires or components can increase the risk of personal injury, fire, or machine damage. If you identify any wires or components that are damaged while performing a wiring task, it is crucial

to replace them promptly to ensure safety and prevent further issues.

6- Motor Wiring: The motor wiring diagrams provided in the manual may not exactly match your machine's configuration. If you find discrepancies, consult the wiring diagram inside the motor junction box for accurate information.

7- Capacitors/Inverters: Some capacitors and power inverters can store an electrical charge for a significant duration (up to 10 minutes) after being disconnected from the power source. To reduce the risk of electrical shock, wait for at least this duration before working on capacitors.

8- Experiencing Difficulties: If you encounter difficulties understanding the information presented in this section or require assistance with your machine's wiring, don't hesitate to contact Technical Support for guidance and clarification. Following these additional warnings and guidelines will help ensure that you work safely with your machine's electrical components and effectively address any wiring-related issues that may arise. Prioritize safety when handling electrical systems and components.

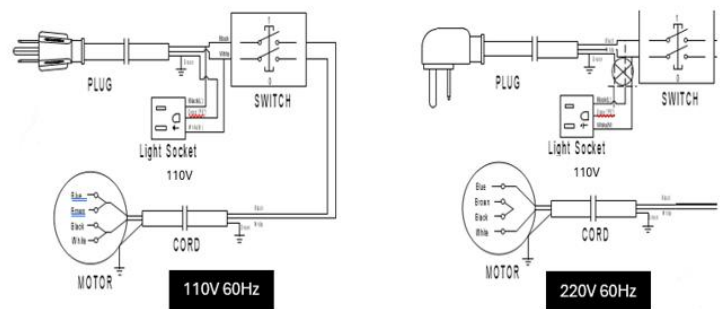

Figure 40: Electrical Diagram.

**Disconnect the Machine from Power Source:\*\* Ensure the machine is disconnected from the power source (wall socket) before performing any maintenance or electrical work. This precaution prevents accidental activation of the machine.**



# Section 9: Machine Diagrams and Parts

While we strive to maintain a comprehensive inventory of replacement parts, it's important to note that availability may vary. We cannot guarantee that all the parts depicted in our inventory are always available for purchase. To ensure you can acquire the specific parts you need, we recommend reaching out to our customer service or technical support team for the most up-to-date information on part availability. Your satisfaction is our priority, and we are here to assist you in every way possible.

## Frame Assembly

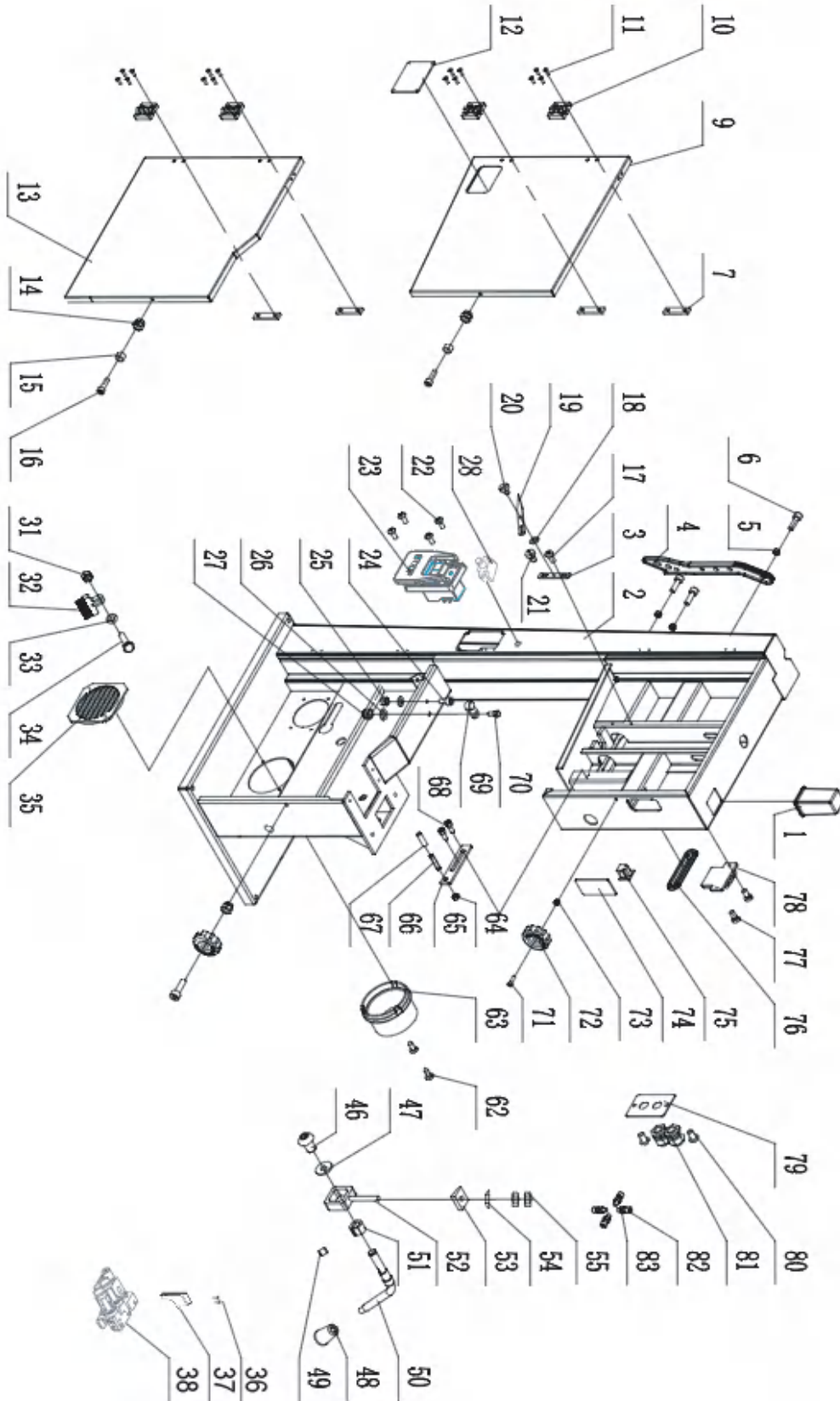

Figure 41: Frame Assembly



## Frame Parts List

Key	Part Number	Description	Qty
1	PBBPBS1401	Guidepost cap	1
2	PBBPBS1402	Frame	1
3	PBBPBS1403	Indicator adjustment plate	1
4	PBBPBS1404	Push stick	1
5	ZHXNM06100	Hex nut M6	3
6	ZCHSM610030	Hex socket cap screw M6x30	3
7	PBBPBS1407	Threaded plate	4
9	PBBPBS1409	Upper wheel cover	1
10	PBBPBS1410	Hinge	4
11	ZCTSM407016	Hex countersunk head screw M4x16	16
12	PBBPBS1412	Clear window	1
13	PBBPBS1413	Lower handwheel door	1
14	ZNYNM060100	Nylon nut M6-1.0	2
15	PBBPBS1415	Bushing $\Phi 6.2 \times 6$	2
16	ZCHSM610020	Hex socket cap screw M6x20	2
17	ZPHSM508010	Pan head screw M5x10	1
18	ZFWM0500000	Washer M5	2
19	PBBPBS1419	Pointer	1
20	ZSPSM508004	Special screw M5X4	1
21	ZHXBMS508005	Fixed pan bolt M5X5	1
22	ZPHSM407020	Pan head screw M4x20	4
23	PBBPBSN1423	ON/OFF switch	1
24	ZCHSM508010	Hex socket cap screw M5x10	1
25	ZHXNM508000	Nut M5	1
26	ZFWM0800000	Washer M8	1
27	ZNYNM080125	Nylon nut M8	1
28	PBBPBS1428	Overload protector	1
31	PBBPBS1431	Self-locking nut M6	1
32	PBBPBS1432	Brush	1
33	ZFWM0600000	Washer M6	1
34	ZHXBMS610025	Hex bolt M6x25	1
35	PBBPBS1435	Dust port grille	1
36	ZPHSM407006	Pan head screw M4x6	2
37	PBBPBS1437	Lower guide guard	1
38	PBBPBS1438	Lower guide assembly	1
46	ZPHSM812512	Pan head screw M8x12	1
47	ZFWM080LRG0	Big washer M8	1
48	PBBPBS1448	Quick release rod	1
49	ZSTSM812508	Set screw M8x8	1
50	PBBPBS1450	Camshaft	1
51	PBBPBS1451	Cam	1



Key	Part Number	Description	Qty
52	PBBPBS1452	Slide bracket	1
53	PBBPBS1453	Spacer	1
54	ZFWM100000	Washer M10	1
55	ZHXNM101500	Nut M10	2
62	ZTPSST35095	Tapping screw ST3.5x9.5	2
63	PBBPBS1463	Dust port	1
64	ZHXNM060100	Nut M6	1
65	PBBPBS1465	Connecting plate	1
66	ZSTSM010030	Set screw M6x30	1
67	PBBPBS1467	Plastic pipe	1
68	ZHXNM050800	Nut M5x12	1
69	PBBPBS1469	Table angle stop block	1
70	PBBPBS1470	Stud shaft	1
71	ZCHSM508025	Hex socket cap screw M6x25	2
72	PBBPBS1472	Star knob $\Phi$ 60x20	2
73	ZNYNM060100	Nylon nut M6-1.0	2
74	PBBPBS1474	Clear window	1
75	PBBPBS1475	Plug seat	1
76	PBBPBS1476	Rubber cover	1
77	ZPHSM508010	Pan head screw M5x10	2
78	PBBPBS1478	Tool holder	1
79	PBBPBS1479	Strain relief plate 100X65	1
80	ZPHSM610010	Pan head screw M6x10	2
81	PBBPBS1481	Strain relief M20	2
82	ZCHSM812525	Hex socket cap screw M8x25	4
83	ZHXNM080125	Nut M8	4



Table Assembly

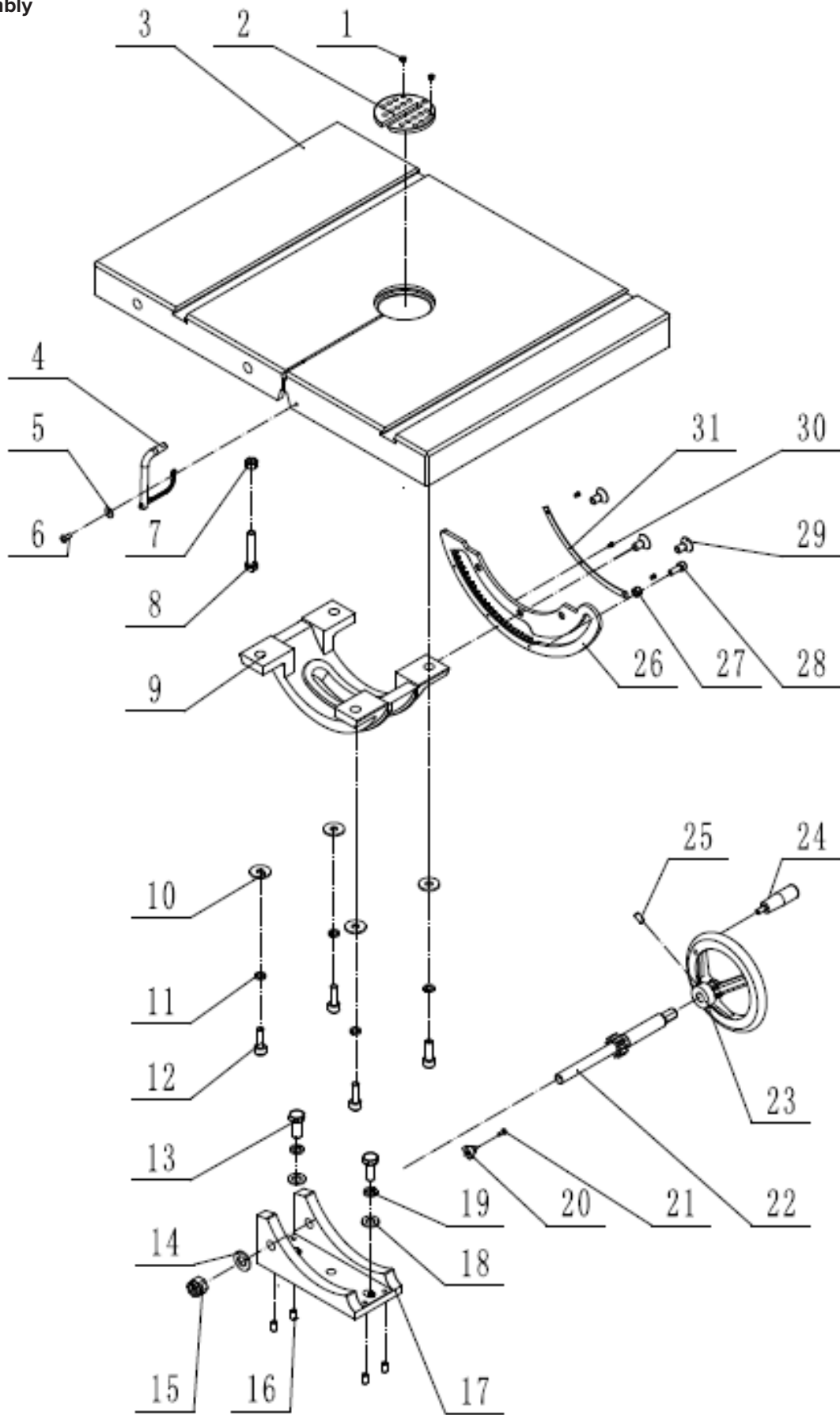

Figure 42: Table Assembly.

## Table Assembly Parts List

Key	Part Number	Description	QTY
1	ZSTSM610004	Set screw M6x4	2
2	PBBPBS14102	Table insert	1
3	PBBPBSN14103	Table	1
4	PBBPBS14104	Table alignment pin & lanyard	1
5	ZFWM0400000	Washer M4	1
6	ZPHSM407010	Pan head screw M4x10	1
7	ZHXNM080125	Hex nut M8	1
8	ZHXB812550	Hex bolt M8x50	1
9	PBBPBS14109	Table trunnion	1
10	ZFWM0800000	Washer M8	4
11	ZSWM0800000	Spring washer M8	4
12	ZCHSM812525	Hex socket cap screw M8x25	4
13	ZHXB1015025	Hex bolt M10x25	2
14	ZFWM1200000	Flat washer M12	1
15	ZHXNM120175	Hex self-locking nut M12	1
16	ZSTSM610012	Set screw M6x12	4
17	PBBPBS14117	Trunnion support	1
18	ZFWM1000000	Flat washer M10	2
19	ZSWM1000000	Spring washer M10	2
20	PBBPBS14120	Pointer	1
21	ZPHSM305005	Pan head screw M3x5	1
22	PBBPBS14122	Gear shaft	1
23	PBBPBS14123	Crank handwheel D125-d12	1
24	PBBPBS14124	Small handle	1
25	ZSTSM610012	Set screw M6x12	1
26	PBBPBS14126	Rack	1
27	PBBPBS14127	Eccentric bushing	1
28	PBBPBS14128	Hex socket cap screw M6x16	1
29	PBBPBS14129	Hex countersunk head screw M8x16	3
30	PBBPBS14130	Rivet 2D5x5	3
31	PBBPBS14131	Angle scale label	1



Blade Guard Assembly

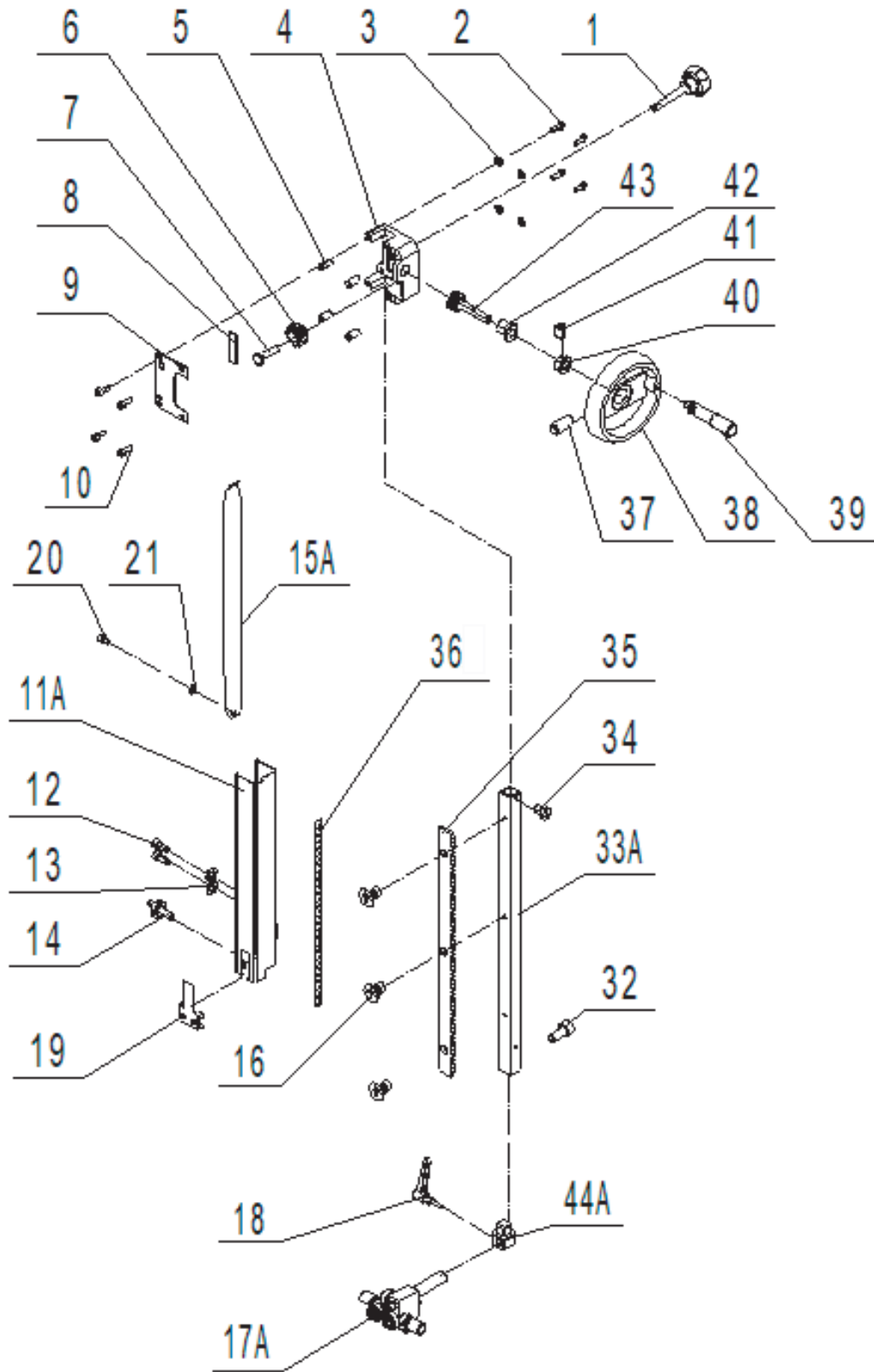

Figure 43: Blade Guard Assembly.

## Blade Guard Assembly Parts List

Key	Part Number	Description	QTY
1	PBBPBS14301	Locking handle $\Phi$ 48-M8-1.25x25	1
2	ZHXB M610016	Hex bolt M6-1.00x16	4
3	ZFWM0600000	Big washer M6	4
4	PBBPBS14304	Guide bracket	1
5	ZSTSM610012	Set screw M6-1.00x12	4
6	PBBPBS14306	Gear m2 z14	1
7	ZXBM1015033	Fixed bolt M10-1.5x33	1
8	PBBPBS14308	Fixed plate	1
9	PBBPBS14309	Guide bracket cover	1
10	ZCHSM610016	Hex socket cap screw M6-1.00x16	4
11A	PBBPBSN14311A	Hinged door	1
12	ZCHSM508012	Hex socket cap screw M5-0.8x12	2
13	ZFWM0500000	Washer M5	2
14	PBBPBS14314	Locking handle $\Phi$ 25-M6-1.00x13	1
15A	PBBPBSN14315A	Spring piece	1
16	ZCTSM508008	Hex countersunk head screw M5-0.8x8	3
17A	PBBPBSN14317A	Upper Guide assembly	1
18	PBBPBSN14318	Locking handle	1
19	PBBPBSN14319	Clear window	1
20	PBBPBSN14320	Hex socket cap screw M6-1.00x10	1
21	PBBPBSN14321	Washer M6	1
32	ZCHSM508025	Hex socket cap screw M5X25	1
33A	PBBPBSN14333A	Guidepost 22x22x499	1
34	ZPHSM508008	Pan head screw M5-0.8X8	1
35	PBBPBS14335	Gear rack	1
36	PBBPBS14336	Scale	1
37	ZSTSM610012	Set screw M6-1.00X12	1
38	PBBPBS14338	Crank handwheel D100-d10	1
39	PBBPBS14339	Handwheel handle	1
40	PBBPBS14340	Set collar	1
41	ZSTSM508008	Set screw M5-0.8x8	1
42	PBBPBS14342	Bushing M18-1.5x12	1
43	PBBPBS14343	Worm cylinder m2	1
44A	PBBPBSN14344A	Bracket seat	1



Blade Tensioning Assembly

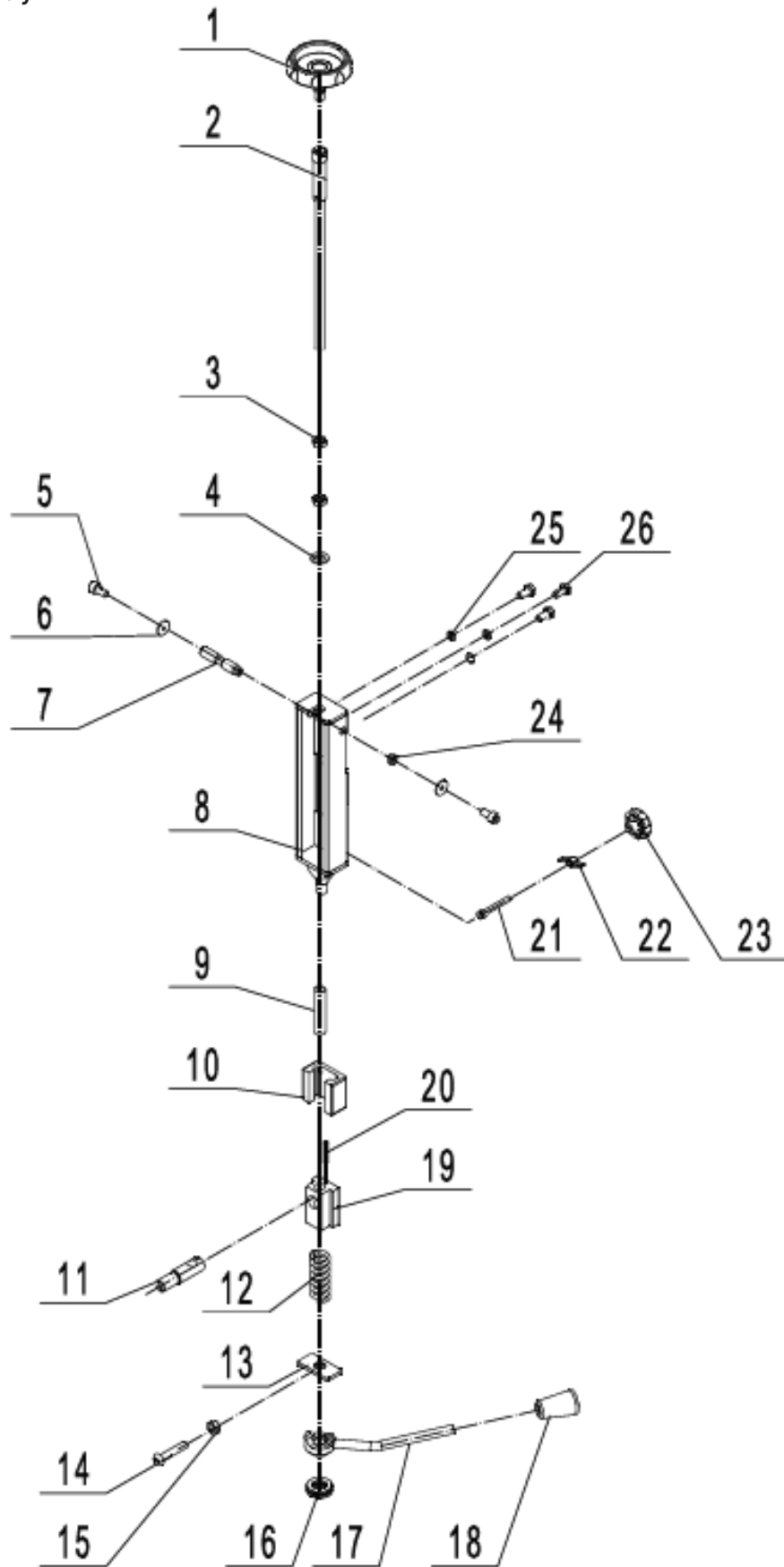

Figure 44: Blade Tensioning Assembly.

## Blade Tensioning Assembly Parts List

Key	Part Number	Description	QTY
1	PBBPBS14201	Blade tension handwheel	1
2	PBBPBS14202	Blade tension rod	1
3	PBBPBS14203	Special hex nut Tr12x2	2
4	ZFWM1200000	Washer M12	2
5	ZCHSM610012	Hex socket cap screw M6x12	2
6	ZFWM0600000	Washer M6	2
7	PBBPBS14207	Upper shaft	1
8	PBBPBS14208	Slide bracket	1
9	PBBPBS14209	Tube	1
10	PBBPBS14210	Sliding Rail	1
11	PBBPBS14211	Upper wheel shaft	1
12	PBBPBS14212	Spring $\Phi 26 \times 70$	1
13	PBBPBS14213	Block	1
14	ZPHSM305016	Pan head screw M3x16	1
15	ZHXNM030500	Hex nut M3	1
16	PBBPBS14216	Thrust bearing 51104	1
17	PBBPBS14217	Quick release lever handle	1
18	PBBPBS14218	Quick release rod	1
19	PBBPBS14219	Upper wheel shaft hinge	1
20	ZSPN0502400	Roll pin 5x24	1
21	PBBPBS14221	Quick stop bolt M10x80	1
22	ZWGNM101500	Wing nut M10	1
23	PBBPBS14223	Blade tracking handle	1
24	ZFWM0610000	Washer 10X6	1
25	ZSWM0600000	Spring washer M6	3
26	ZHXB610012	Hex Bolt M6x12	3



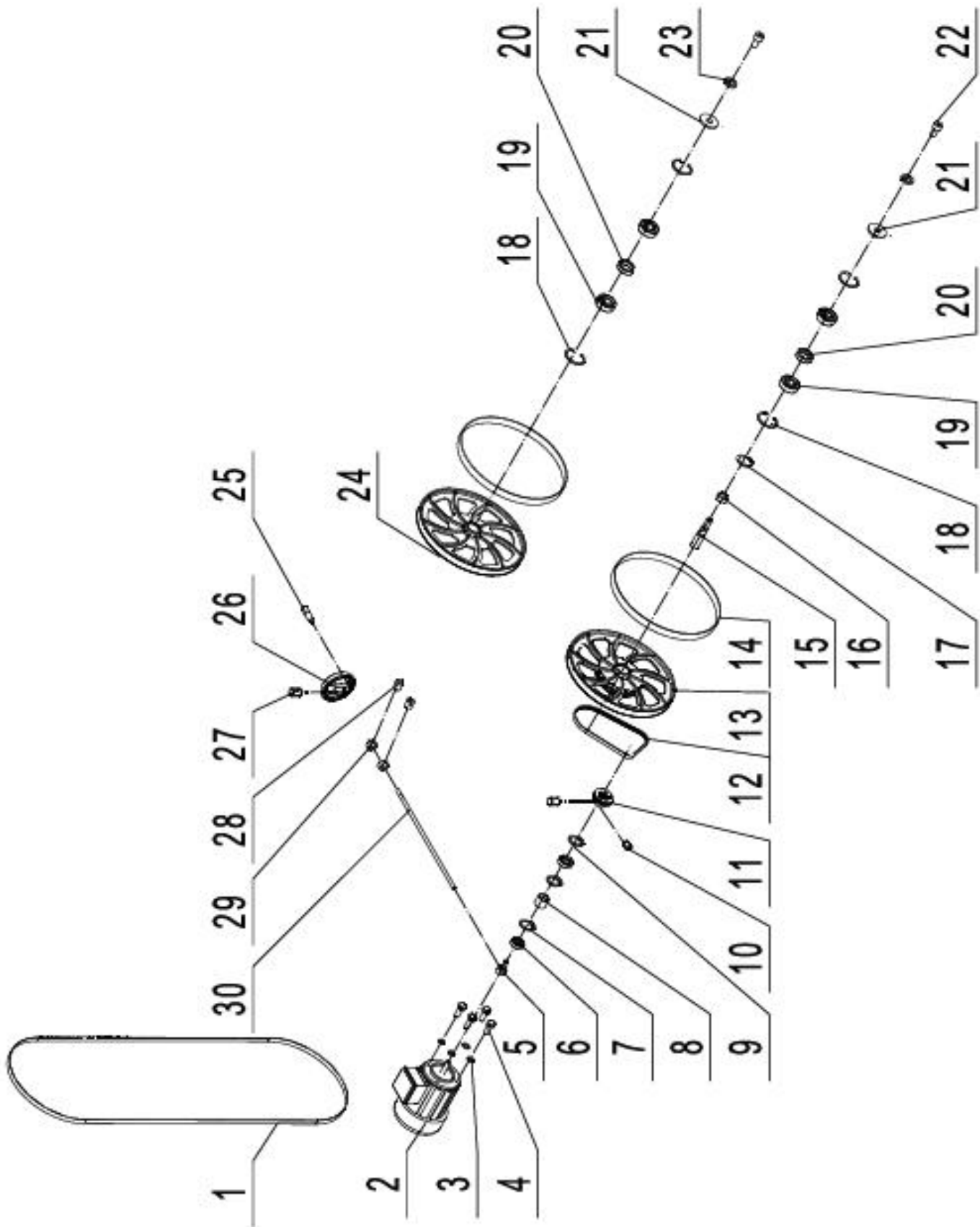

Figure 45: Motor and Wheel Assembly

## Motor and Wheel Assembly Parts List

Key	Part Number	Description	QTY
1	PBBPBS14401	Bandsaw blade 16x2820±3	1
2	BBPBS14MOT	Motor 120V/60Hz/1PH/2HP	1
3	XFWM0600000	Big washer M6	2
4	ZHXB610016	Hex bolt M6-1.00x16	2
5	PBBPBS14405	Sliding shaft	2
6	ZBRG0ZZ6001	Bearing 6001	2
7	ZCRI0280000	Retainer ring Internal 28	1
8	PBBPBS14408	Tension wheel	1
9	ZCRE0120000	Retaining ring External 12	1
10	ZSTSM610008	Set screw M6-1.00x8	1
11	PBBPBS14411	Motor pulley 14	1
12	PBBPBS14412	Multi-Vee belt 4PJ615	1
13	PBBPBS14413	Lower bandsaw wheel	1
14	PBBPBS14414	Tire	1
15	PBBPBS14415	Lower wheel shaft	1
16	ZHXNM201500	Hex nut M20-1.50	1
17	ZCRE0170000	Retaining ring External 17	1
18	ZCRI0400000	Retaining ring Internal 40	1
19	ZBRG0ZZ6203	Bearing 6203	1
20	PBBPBS14420	Tube	1
21	ZFWM0800000	Washer M8	1
22	ZCHSM812516	Hex socket cap screw M8-1.25x16	1
23	ZSWM0800000	Spring washer M8	1
24	PBBPBS14424	Upper bandsaw wheel	1
25	PBBPBS14425	Handwheel handle	3
26	PBBPBS14426	Crank handwheel	3
27	ZSTSM610008	Set screw M6-1.00x8	
28	ZSTSM508008	Set screw M5-0.80x8	
29	PBBPBS14429	Set collar	
30	PBBPBS14430	Crank	
31	ZRCA50450	Run Capacitor 50µF-450VAC 2"X3-3/4"	
32	ZSCA150300	Start Capacitor 150µF-350VAC 1-3/4X3-3/4"X3-1/8"	



## Cabinet Assembly

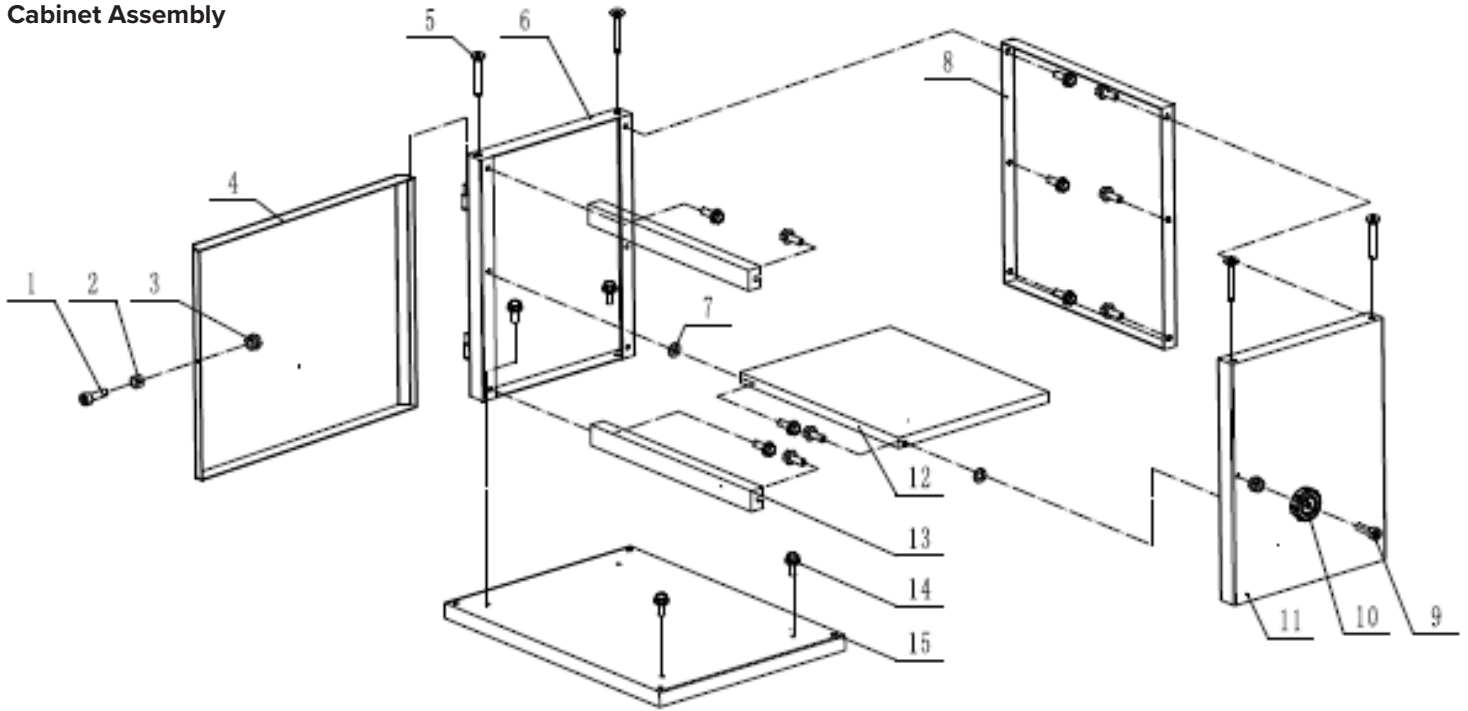

Figure 46: Cabinet Assembly.

## Cabinet Assembly Parts List

Key	Part Number	Description	QTY
1	ZCHSM610016	Hex socket cap screw M6-1.00X16	1
2	PBBPBS14602	Bushing $\Phi 6.2 \times 6$	1
3	ZFGNM060100	Self-locking nut M6-1.00	2
4	PBBPBSN14604	Door assembly	1
5	ZCTSM610040	Hex countersunk head screw M6-1.00X40	4
6	PBBPBS14606	Left side panel	1
7	ZFWM080LRG0	Big washer M8	2
8	PBBPBS14608	Back side panel	1
9	ZCHSM610020	Hex socket cap screw M6-1.00X20	1
10	PBBPBS14610	Handlebar	1
11	PBBPBS14611	Right side panel	1
12	PBBPBS14612	Plate	1
13	PBBPBS14613	Beam	2
14	ZFGBM812520	Hex bolt with flange M8-1.25X20	16
15	PBBPBS14615	Base board	1

## Rip Fence & Rails Assembly

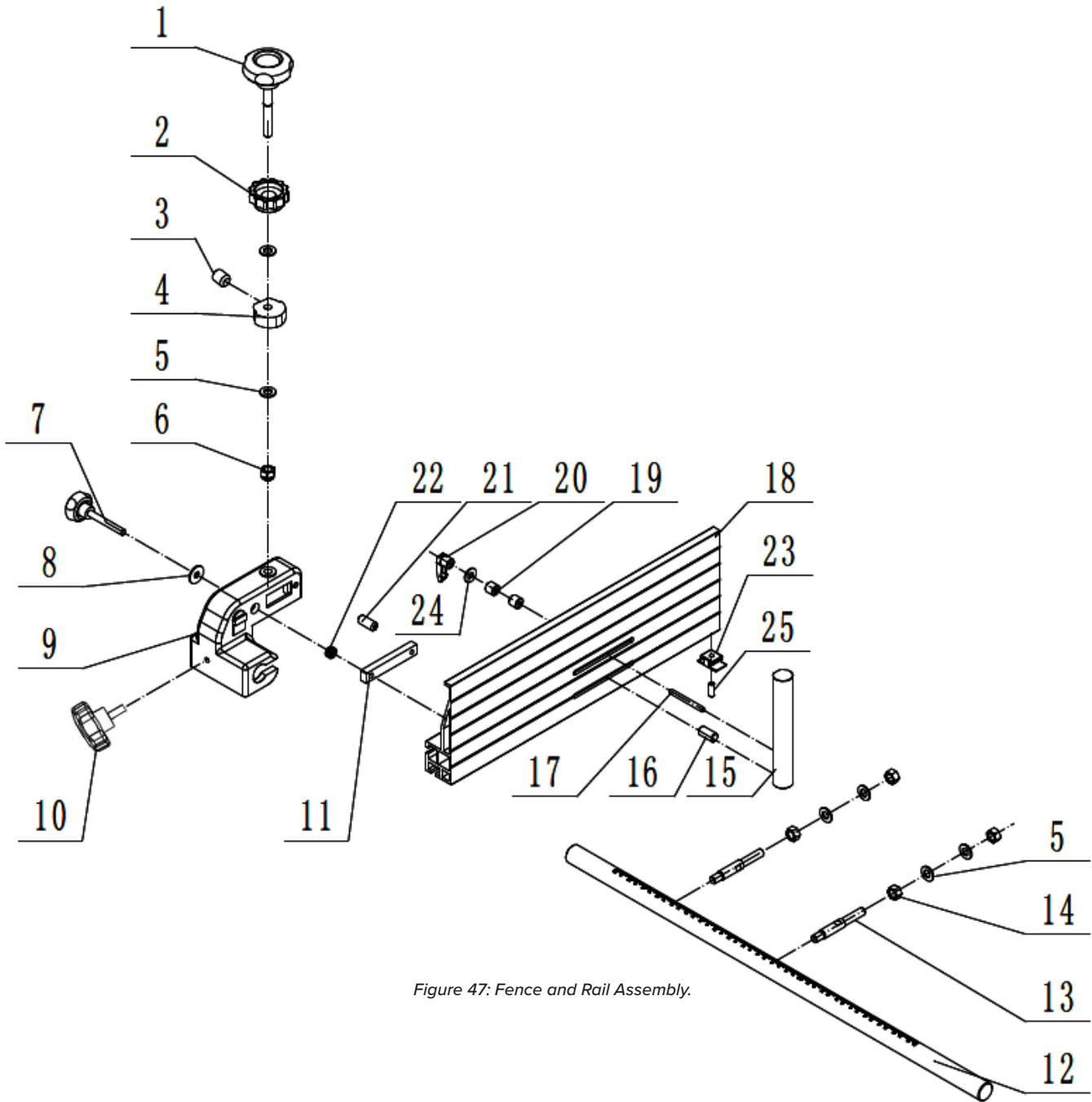

Figure 47: Fence and Rail Assembly.

### Rip Fence & Rails Assembly Parts List

Key	Part Number	Description	QTY
1	PBBPBS14501	Adjusting handle M10	1
2	PBBPBS14502	Straight grain handle	1
3	ZSTSM812510	Set screw M8X10	1
4	PBBPBS14504	Cam	1
5	ZFWM1000000	Washer M10	6
6	ZLKNM101500	Hex lock nut M10	1
7	PBBPBS14507	Round handle	1



Key	Part Number	Description	QTY
8	ZFWM0800000	Washer M8	1
9	PBBPBS14509	Fence carrier	1
10	PBBPBS14510	Adjust knob M8	1
11	PBBPBS14511	Sliding block	1
12	PBBPBS14512	Guide rail	1
13	PBBPBS14513	Connecting rod	2
14	ZHXNM101500	Hex nut M10-1.50	4
15	PBBPBS14515	Re-saw bar	1
16	ZSTSM610012	Set screw M6-1.00x12	1
17	ZSTSM610058	Set screw M6-1.00x58	1
18	PBBPBS14518	Fence	1
19	PBBPBS14519	Cover	2
20	PBBPBS14520	Lock knob M6	1
21	ZSPN0600260	Spring pin 6x26	1
22	PBBPBS14522	Spring $\Phi$ 11x12	1
23	PBBPBS14523	Nylon plate	1
24	ZFWM600000	Washer M6	1
25	ZSTSM610016	Set screw M6-1.00X16	1

## Section 10: Troubleshooting

Issue	Possible Cause	Solution
The machine will not start when turned on	<ol style="list-style-type: none"> <li>1. No power supply.</li> <li>2. Defective switch</li> </ol>	<ol style="list-style-type: none"> <li>1. Check the cable for damage and check power source.</li> <li>2. Contact customer service for warranty replacement switch.</li> </ol>
The blade will not move with the motor running	<ol style="list-style-type: none"> <li>1. The quick release lever or the blade tension handwheel are not tight.</li> <li>2. The blade is off the wheels.</li> <li>3. The saw blade is broken.</li> <li>4. The drive belt is snapped.</li> </ol>	<ol style="list-style-type: none"> <li>1. Switch off the machine tighten the quick release lever or tension the handwheel.</li> <li>2. Open both doors and check the blade re-install if necessary.</li> <li>3. Replace the blade.</li> <li>4. Replace the belt.</li> </ol>
The blade will not cut, or it cuts very slowly.	<ol style="list-style-type: none"> <li>1. Not using the fence</li> <li>2. The blade has gone dull or damaged.</li> <li>3. The feed rate is too fast.</li> <li>4. The blade guide isn't adjusted correctly.</li> <li>5. The orientation of the teeth is incorrect.</li> </ol>	<ol style="list-style-type: none"> <li>1. Use the fence.</li> <li>2. Replace damaged or dull blade with a new one.</li> <li>3. Reduce the feed rate by applying less pressure on the workpiece.</li> <li>4. Adjust the blade guide to a ¼" height over the workpiece.</li> <li>5. Re-install the blade correctly.</li> </ol>



Issue	Possible Cause	Solution
The saw dust is building up inside the machine	<ol style="list-style-type: none"> <li>1. Excessive on the exterior of the machine</li> <li>2. Excessive dust buildup inside the machine and motor housing components.</li> </ol>	<ol style="list-style-type: none"> <li>1. A regular cleanup must be performed use a shop vac to remove all the dust from and around the machine, make sure that you are using the correct dust collection requirement.</li> <li>2. Regularly clean the ventilation fan cover and the motor with a shop vac. The saw dust must be removed regularly to prevent it from entering the motor.</li> </ol>
The table isn't perpendicular to the blade	<ol style="list-style-type: none"> <li>1. The table alignment is off.</li> <li>2. The blade is dull, and damage was done to it by putting too much pressure.</li> </ol>	<ol style="list-style-type: none"> <li>1. Readjust the table; please see setup section for step-by-step instructions.</li> <li>2. Replace damaged blade immediately.</li> </ol>
The band wheels are not aligned	<ol style="list-style-type: none"> <li>1. The wheels are not aligned.</li> <li>2. The blade tracking knob isn't adjusted properly.</li> <li>3. Blade quality is inferior.</li> </ol>	<ol style="list-style-type: none"> <li>1. Readjust the table; please see setup section for step-by-step instructions.</li> <li>2. Replace damaged blade immediately.</li> </ol>

### Changing the Motor Drive Belt

Before changing the belt, ensure the bandsaw is unplugged from the power source. Follow these steps to change the drive belt:

1. Release the tension on the bandsaw blade and move the blade off the lower wheel or remove the blade entirely from the saw.
2. Remove the tension from the drive belt by turning the belt tensioning Handwheel. Remove the old belt from the wheel and pulleys.
3. Remove the Lower Wheel from the saw by taking out the Allen Screw, Spring Washer, and Flat Washer in the center of the lower wheel. Carefully pull the wheel off the shaft.
4. Install the new belt and reverse the process outlined above. Tension the drive belt until there is 3/8" to 1/2" of deflection see

### Leveling the Table Insert

The table insert has a built-in micro-adjustment feature for precise leveling. Follow these steps to adjust the table insert:

- 1- If the insert is above the table: Turn the micro-screws counterclockwise with a hex "L" wrench to lower the insert.
- 2- If the insert is below the table: Turn the micro-screws

clockwise to raise the insert level with the table.

Caution: An insert below the tabletop could cause the workpiece to get stuck on the lip of the table seat, especially at the back area behind the blade.



*An insert below the tabletop could cause the workpiece to get stuck on the lip of the table seat, especially at the back area behind the blade.*

### Changing Bandsaw Tires

#### 1- Remove the Old Tire:

- Use a putty knife to lift and pull the tire away from the wheel.
- Work the putty knife around the wheel to fully loosen the tire.
- Use the putty knife as leverage to flip the tire off the wheel.
- Clean the inside of the wheel groove, removing any dirt, debris, or cement with lacquer thinner.

## 2- Install the New Tire:

- Soak the replacement tire in warm water to increase flexibility.
- Dry the tire, and while it is still warm, place it on top of the wheel.
- Start by setting the tire into the wheel groove at the top of the wheel.
- Use a putty knife to work the new tire around the wheel, being careful not to slice the tire.
- If using rubber cement as a binder, apply it evenly. Ensure there are no high spots between the wheel and the tire, as this will cause vibration and affect blade tracking.

## Lower Wheel Adjustments

The following instructions are essential for correcting common blade issues related to the alignment of the lower wheel in relation to the upper wheel. These adjustments address blade position on the lower wheel and blade oscillation, which significantly impact the bandsaw's performance and accuracy.

*Please Read and Understand these Steps Completely Before Making Any Adjustments. Failure to do so could damage the machine.*

If you have questions, please contact our customer service or tech support:

Busy Bee Tools Head Office  
130 Great Gulf Drive  
Concord ON, L4K 5W1

Or at any of our branches across Canada.

Visit our website for the latest deals and for more information. Call us Toll Free: 1-800-461-2879 leave a message with the issue you are facing a customer service representative will get back to you within 2 days, or

Email us at: [cs@busybeetools.com](mailto:cs@busybeetools.com)

### Procedure:

- 1- Release Blade Tension: Completely release the tension on the blade before making any lower wheel adjustments. Pressure must be released on the lower wheel to allow proper adjustments and to avoid damaging the machine.
- 2- Identify the Issue: If the blade is not running true or is not centered on the lower wheel but is correct on the upper wheel, an adjustment to the lower wheel hub on the rear of the bandsaw is required. Follow the steps below.

## Adjustment Steps:

- 1- De-tension the saw blade.
- 2- Loosen the 9 o'clock shaft bolt to relieve pressure on the shaft.
- 3- Loosen the 12 o'clock shaft bolt by half a rotation.
- 4- Tighten the 6 o'clock shaft bolt until the shaft touches the 12 o'clock adjusting bolt.
- 5- Lock all three shaft bolts.
- 6- Re-tension the saw blade and set the upper wheel to plumb by adjusting the tracking knob. Spin the upper wheel by hand and track the blade.
- 7- Repeat if Necessary: If further adjustment is required, repeat the above steps.

## Adjusting Blade Tracking on the Rear of the Lower Wheel

If a blade is tracking on the rear of the lower wheel, away from the door, follow these steps:

- 1- De-tension the saw blade: Release the tension on the saw blade.
- 2- Loosen the 9 o'clock shaft bolt: This relieves pressure from the shaft.
- 3- Loosen the 6 o'clock shaft bolt: Rotate it half a turn.
- 4- Tighten the 12 o'clock shaft bolt: Adjust it until the shaft touches the 6 o'clock adjusting bolt.
- 5- Lock all three shaft bolts: Secure them in place.
- 6- Re-tension the saw blade: Apply tension to the saw blade.
- 7- Set the upper wheel to plumb: Adjust the tracking knob to ensure the upper wheel is plumb. Spin the upper wheel by hand and track the blade.
- 8- Repeat if further adjustment is necessary: If the blade tracking requires further refinement, repeat the adjustment steps.

Following these steps meticulously will help ensure optimal blade tracking on the bandsaw.





# Busy Bee Tools

## BUSY BEE TOOLS 2 YEARS LIMITED WARRANTY

Busy Bee Tools warrants every product to be free from defects in materials and agrees to correct such defects where applicable. This warranty covers **two years** for parts and 90 days for labor (unless specified otherwise), to the original purchaser from the date of purchase but does not apply to malfunctions arising directly or indirectly from misuse, abuse, improper installation or assembly, negligence, accidents, repairs or alterations or lack of maintenance.

***Proof of purchase is necessary.***

All warranty claims are subject to inspection of such products or part thereof and Busy Bee Tools reserves the right to inspect any returned item before a refund or replacement may be issued.

This warranty shall not apply to consumable products such as blades, bits, belts, cutters, chisels, punches etc.

Busy Bee Tools shall in no event be liable for injuries, accidental or otherwise, death to persons or damage to property or for incidental contingent, special or consequential damages arising from the use of our products.

### **RETURNS, REPAIRS AND REPLACEMENTS**

To return, repair, or replace a Busy Bee Tools product, you must visit the appropriate Busy Bee Tools showroom or call 1-800-461-BUSY.

For replacement parts directly from Busy Bee Tools, for this machine, please call 1-800-461-BUSY (2879), and have your model number and part number & payment option ready.

- All returned merchandise will be subject to a minimum charge of 15% for re-stocking and handling with the following qualifications.
- Returns must be pre-authorized by us in writing.
- We do not accept collect shipments.
- Items returned for warranty purposes must be insured and shipped pre-paid to the nearest warehouse
- Returns must be accompanied with a copy of your original invoice as proof of purchase. Returns must be in an un-used condition and shipped in their original packaging a letter explaining your reason for the return. Incurred shipping and handling charges are not refundable.
- Busy Bee will repair or replace the item at our discretion and subject to our inspection.
- Repaired or replaced items will be returned to you pre-paid by our choice of carriers.
- Busy Bee reserves the right to refuse reimbursement or repairs or replacement if a third party without our prior authorization has carried out repairs to the item.
- Repairs made by Busy Bee Tools are warranted for 30 days on parts and labour.
- Any unforeseen repair charges will be reported to you for acceptance prior to making the repairs.
- The Busy Bee Parts & Service Departments are fully equipped to do repairs on all products purchased from us with the exception of some products that require the return to their authorized repair depots. A Busy Bee representative will provide you with the necessary information to have this done.
- For faster service it is advisable to contact the nearest Busy Bee location for parts availability prior to bringing your product in for repairs.

